

Lecture 15

LPWANs Challenges

CS397/497 – Wireless Protocols for IoT
Branden Gena – Winter 2023

With images from Swarun Kumar (CMU)

Materials in collaboration
with Pat Pannuto (UCSD)

Today's Goals

- Consider LPWAN use cases, looking at a particular automotive study
- Explore academic research improving LoRaWAN capabilities
- Deep-dive into challenges LPWANs face

Outline

- **LPWAN Use Cases**
- Improving LoRaWAN
- LPWAN Challenges

Project Background

Research project with automotive company (circa 2019)

LPWAN protocols are potentially interesting for automotive uses

- New design points allow trading bandwidth, range, power, and cost.
- Could these enable new valuable applications?

Problem Statement

- Is there an opportunity to complement existing high-bandwidth low-latency networks, with emerging low-cost long-range networks for certain automotive use cases?
- What new uses cases can be realized by the addition of these new communications capabilities?
- How would future vehicle architectures change to support these networks?

Low-Power Applications

Now

Asset Tracking

- Report location of vehicle prior to sale even when off

Parked Status

- Monitor and report several sensors when vehicle is parked and off

Near

Vehicle Security

- Detect suspicious behavior near the vehicle and report to user

Far

Distributed Data Collection

- Collect sensor data from vehicles throughout a city

Asset Tracking Application

- Track the vehicle's location in real time from factory to point-of-sale.
- Envision a web application that can label each vehicle on a dealer's lot.
- Could be useful to owner as well for theft-tracking purposes.
- Would utilize:
 - GPS
 - Accelerometers (detect if vehicle is in motion)

Parked Status Application

- Alert the user of flat tires, dead batteries, or other issues that can occur while the vehicle is parked and off.
- Envision a smartphone app that could send owners a notification if something goes wrong.
- Would utilize:
 - Tire pressure sensors
 - Battery status sensors
 - Door, trunk, window, and roof opened/closed sensors
 - Fuel level sensor
 - Accelerometers (collision detection)

Vehicle Security Application

- Detect suspicious activity around the vehicle and send notifications to the owner.
- Envision a smartphone app that notifies the owner with a picture of the nearby activity.
- Would be enabled by sensors already in place for vehicle autonomy purposes.
- Would utilize:
 - Cameras
 - Motion sensors
 - Door, trunk, window, and roof opened/closed sensors
 - Accelerometers

Distributed Data Collection Application

- Collect and collate various sensor data from cars parked throughout a region.
- Parked vehicles can be used as a city-scale sensor network to determine various phenomena.
 - Track weather down to local levels.
 - Measure air quality throughout a city.
 - Sense and report nearby traffic congestion.
- This is a little further-term than other applications, but cities and researchers could benefit greatly from available data.

Project Takeaways

Unlicensed LPWANs seem limited in applicability to vehicles

- Coverage areas and bandwidth capabilities are too limited

Cellular LPWANs can enable inactive vehicle applications

- Applications have long lifetimes, even using a backup battery
- Architecture changes to support low-power communications appear feasible

Low-power, inactive-vehicle applications are worth further investigation

- Asset tracking and parked vehicle status are realizable in near-term
- What would the costs of realizing these applications be?
- How much value would they add for customers and company

Break + Brainstorm

- Other applications for automotive use?

Outline

- LPWAN Use Cases
- **Improving LoRaWAN**
- LPWAN Challenges

Resources

- Swarun Kumar (CMU) - <https://swarunkumar.com/lpwan.html>
- Choir
 - <https://swarunkumar.com/papers/choir-sigcomm2017.pdf>
 - <https://swarunkumar.com/slides/choir-sigcomm2017.pdf>
- Charm
 - <https://swarunkumar.com/papers/charm-ipsn2018.pdf>
- Opportunistic Packet Recovery
 - <https://swarunkumar.com/papers/opr-mobisys2020.pdf>

Choir Paper

Empowering Low-Power Wide Area Networks in Urban Settings

Rashad Eletreby
Carnegie Mellon University
Pittsburgh, PA
reletreby@cmu.edu

Swarun Kumar
Carnegie Mellon University
Pittsburgh, PA
swarun@cmu.edu

Diana Zhang
Carnegie Mellon University
Pittsburgh, PA
dianaz1@andrew.cmu.edu

Osman Yağın
Carnegie Mellon University
Pittsburgh, PA
oyagan@andrew.cmu.edu

ABSTRACT

Low-Power Wide Area Networks (LP-WANs) are an attractive emerging platform to connect the Internet-of-things. LP-WANs enable low-cost devices with a 10-year battery to communicate

1 INTRODUCTION

Recent years have witnessed Low-Power Wide Area Networks (LP-WANs) emerge as an attractive communication platform for the Internet of Things (IoT) [37]. LP-WANs enable low-power devices

- SIGCOMM 2017

Choir concept

- Can we distinguish data from LoRa chirps that have collided?
 - Yes! By applying signal processing to the problem

Data in time domain

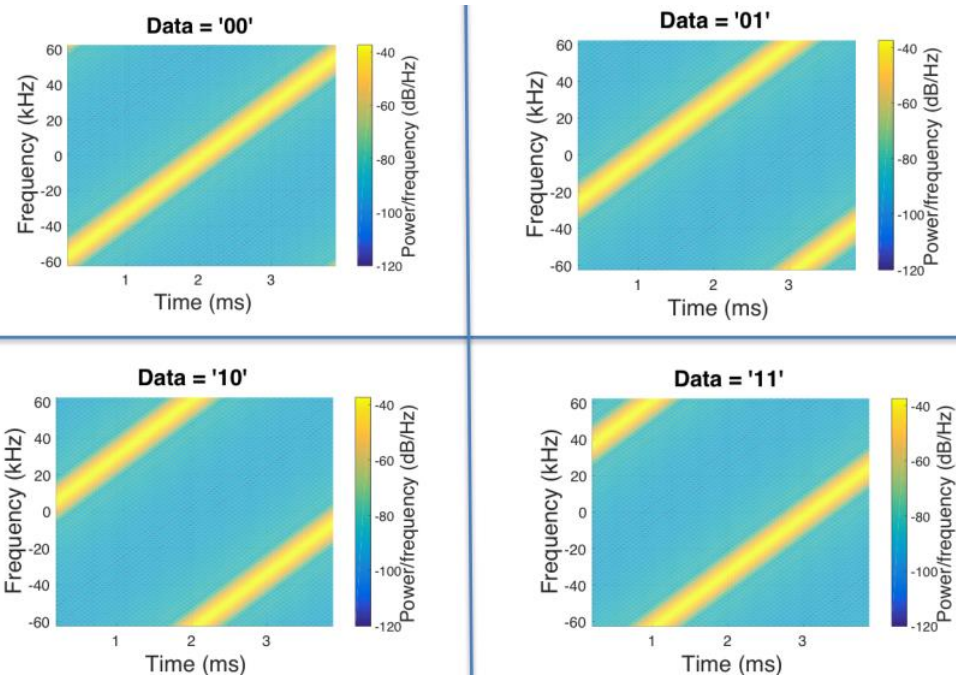

Data in frequency domain

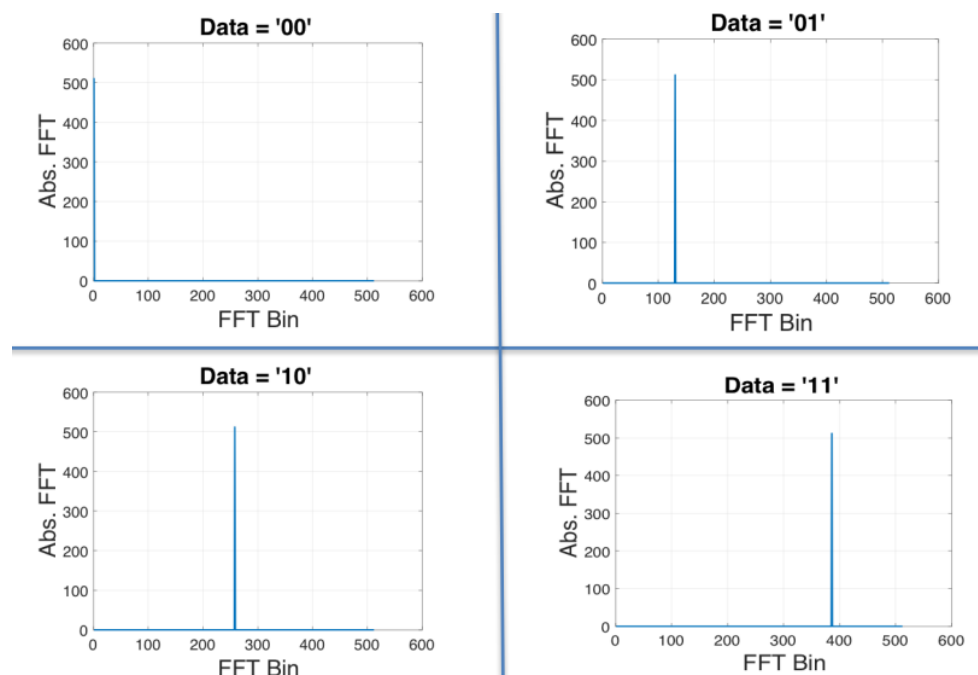

What happens when LoRa chirps collide?

Different data

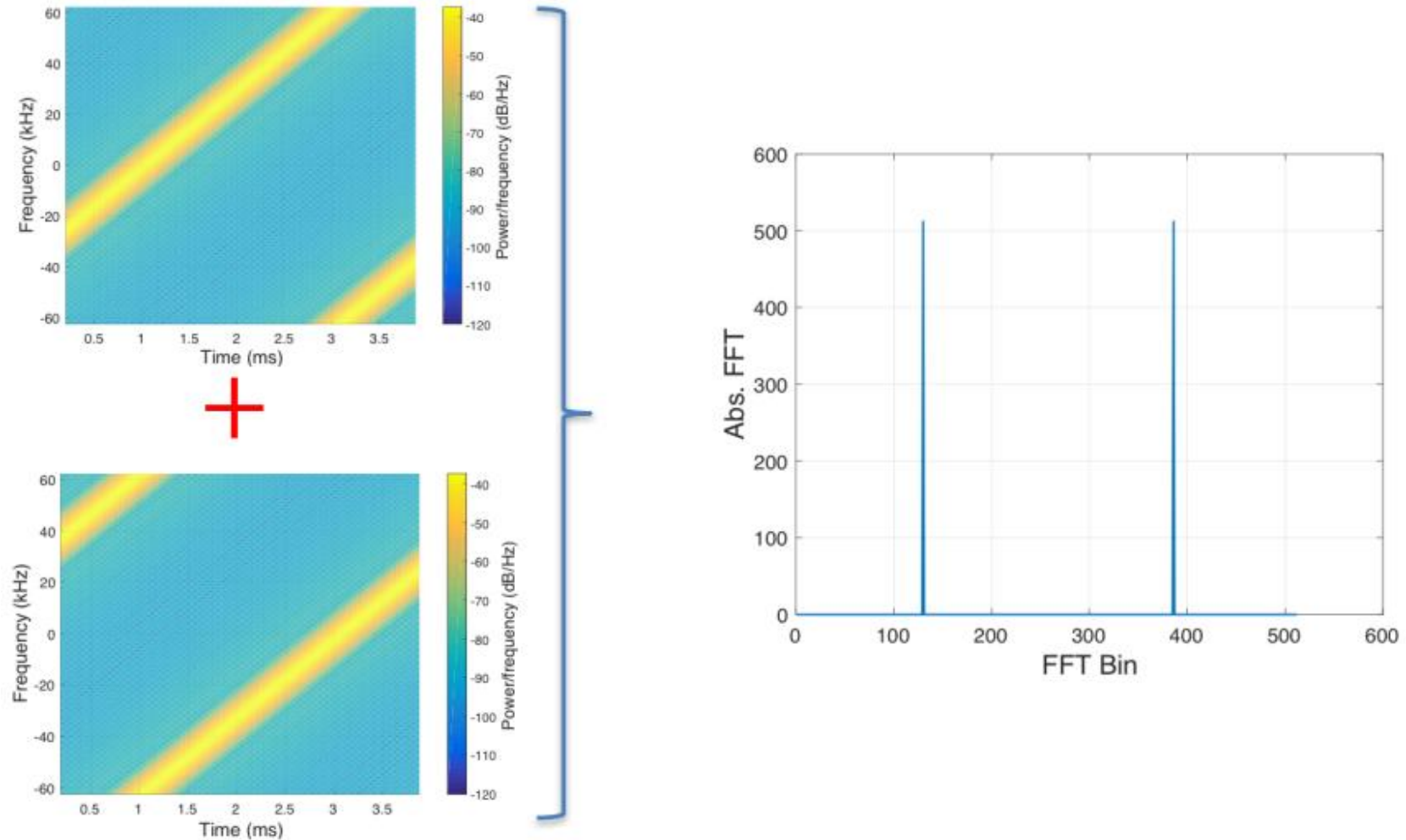

What happens when LoRa chirps collide?

Same data

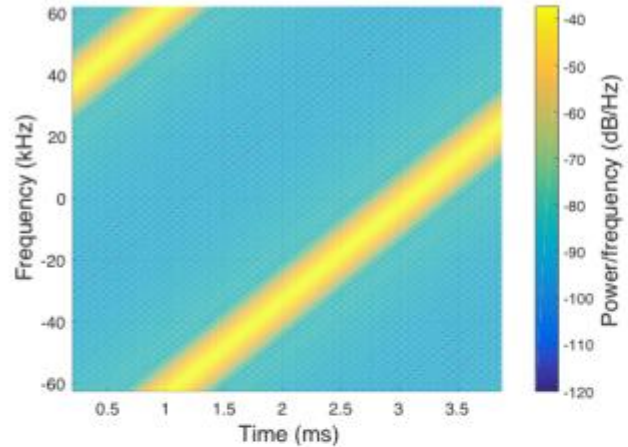

+

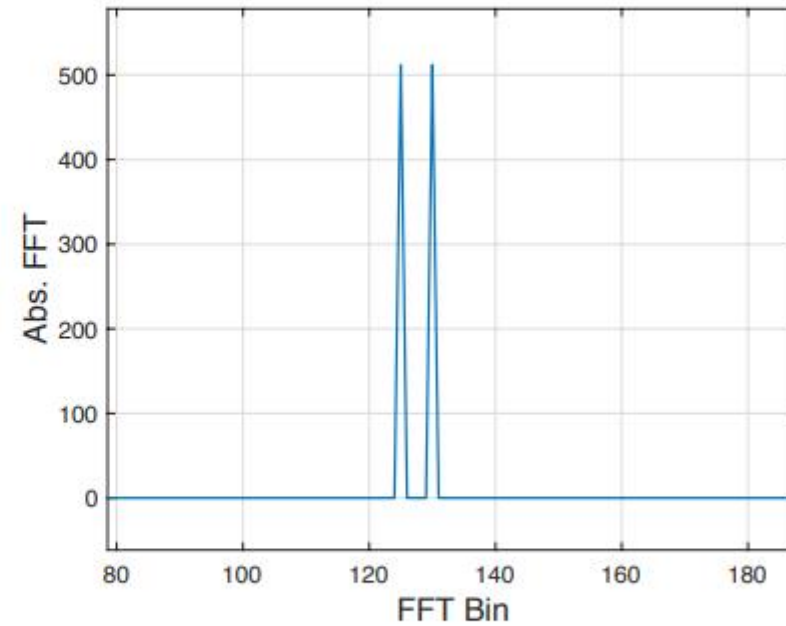
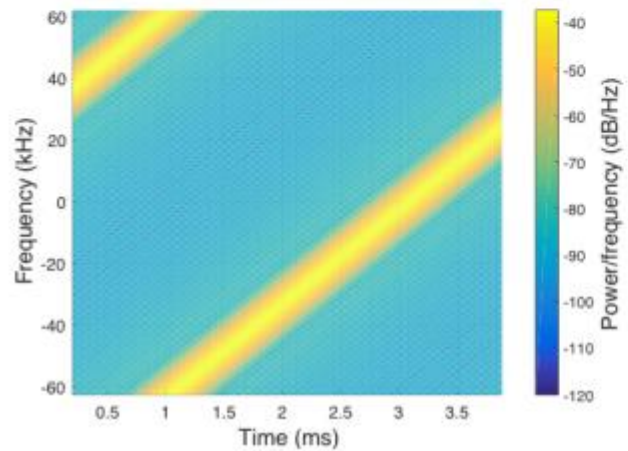

Hardware offsets!

Imperfections in hardware create offsets

Carrier frequency offsets (CFO)

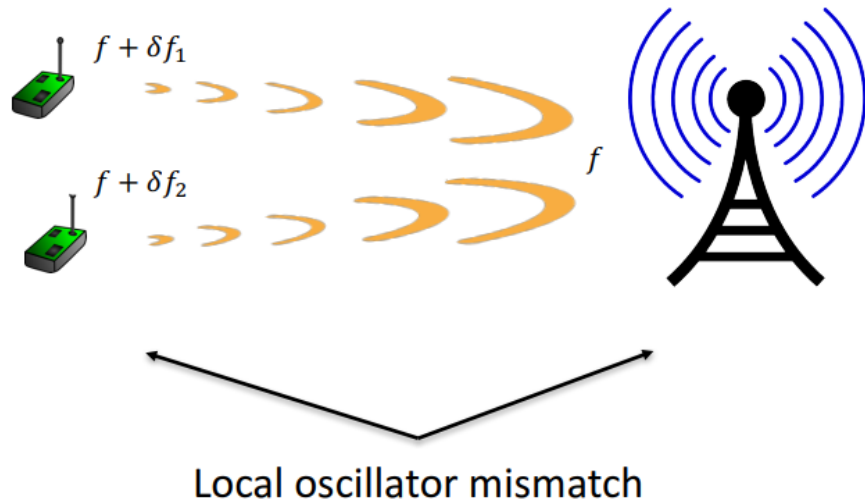

Timing offsets (TO)

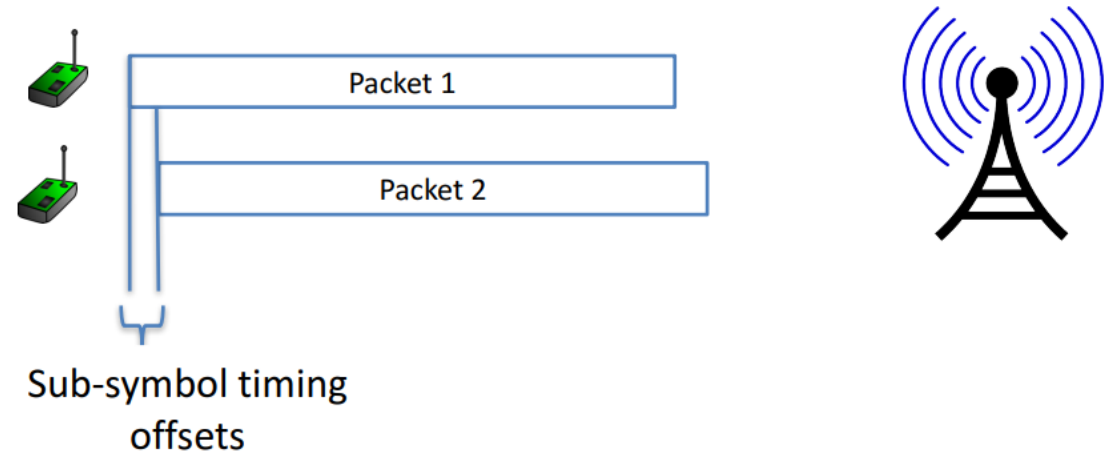

Decoding colliding packets

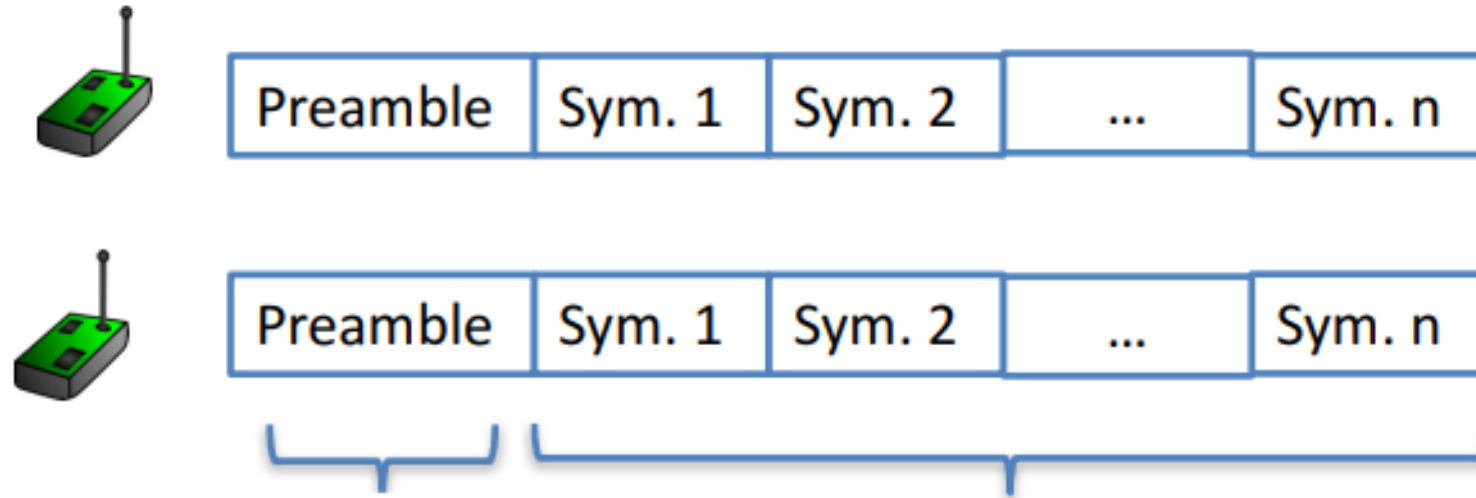

Peak locations are used to estimate hardware offsets

Hardware offsets remain constant across the packet



Choir results

- Recovering collided packets resolves losses due to Aloha transmission!
- Increases maximum throughput on the network considerably!
- Requires hardware modifications on gateways

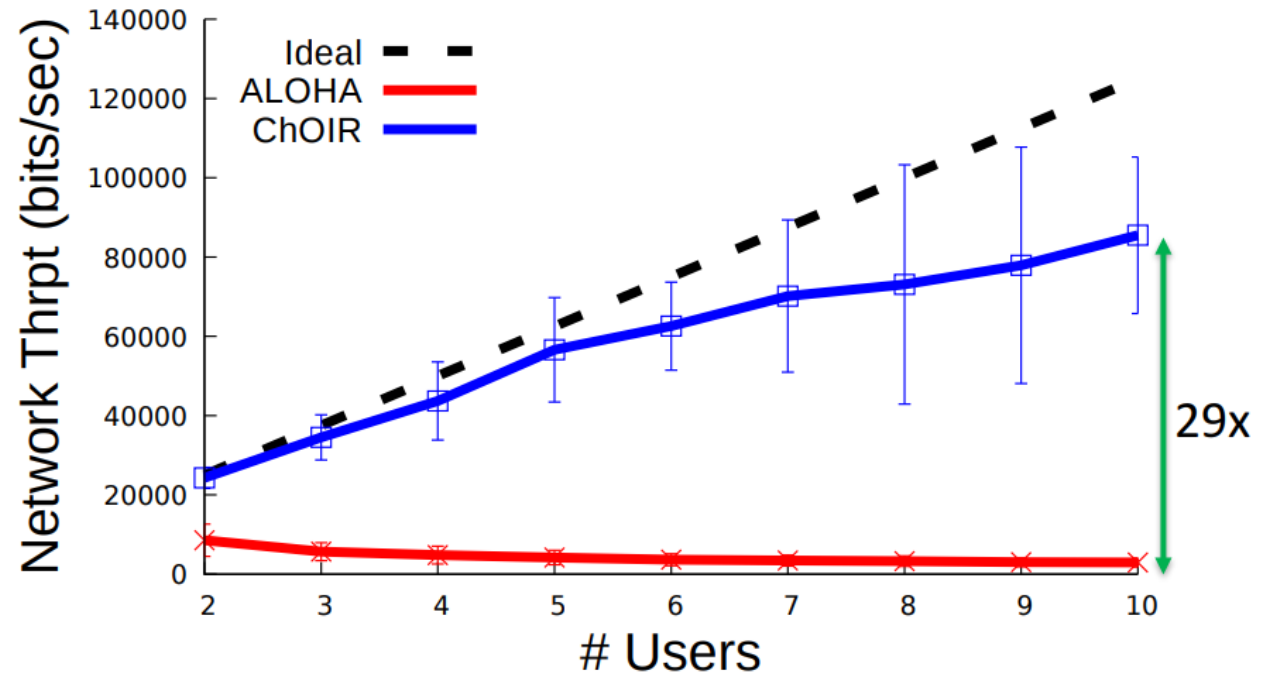

Charm Paper

Charm: Exploiting Geographical Diversity Through Coherent Combining in Low-Power Wide-Area Networks

Adwait Dongare
Carnegie Mellon University
adongare@cmu.edu

Revathy Narayanan
Carnegie Mellon University
IIT Madras
revathyn@andrew.cmu.edu

Akshay Gadre
Carnegie Mellon University
agadre@andrew.cmu.edu

Anh Luong
Carnegie Mellon University
anhluong@cmu.edu

Artur Balanuta
Carnegie Mellon University
Instituto Superior Técnico, Lisbon
artur@cmu.edu

Swarun Kumar
Carnegie Mellon University
swarun@cmu.edu

Bob Iannucci
Carnegie Mellon University
bob.iannucci@west.cmu.edu

Anthony Rowe
Carnegie Mellon University
agr@ece.cmu.edu

ABSTRACT

Low-Power Wide-Area Networks (LPWANs) are an emerging wireless platform which can support battery-powered devices lasting

KEYWORDS

LPWAN, sensor networks, coherent combining, diversity

- IPSN 2018

Charm

- Take advantage of multiple gateways in range of a device
- Combine signals received at each gateway to recover packets that weren't received cleanly
- Particularly useful at decoding weak signals

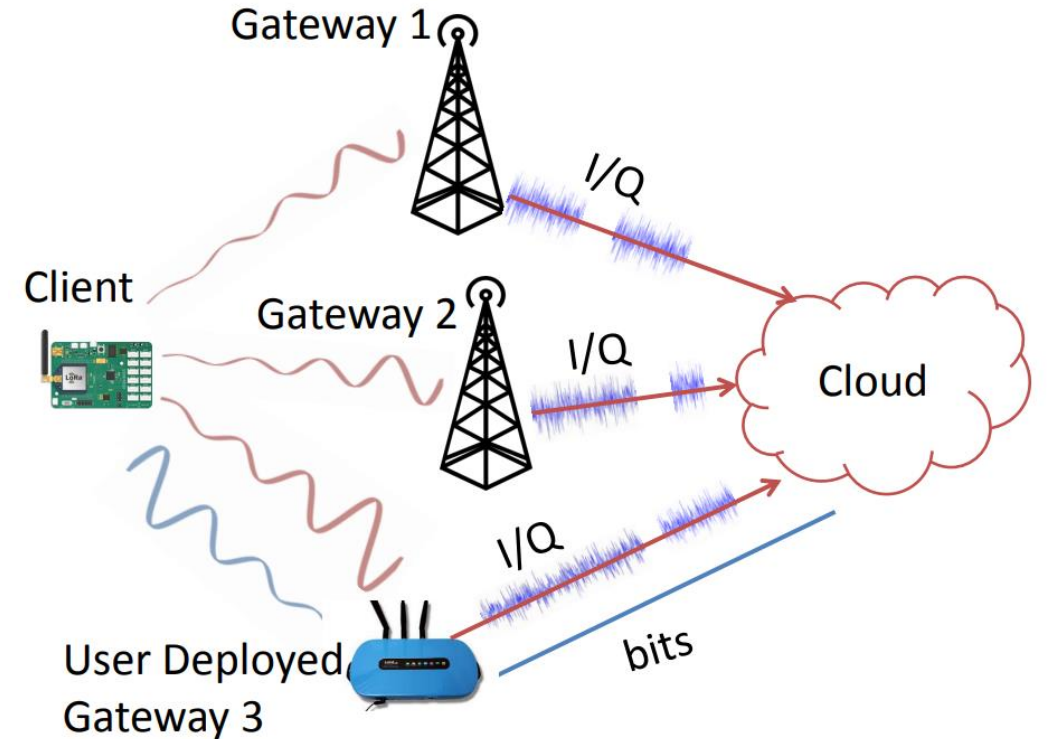

Coherent combining

- Signal received at each receiver is a combination of
 - Signal
 - Wireless channel
 - Random noise
- Signal and wireless channel are similar at all receivers
- Noise is different though!
Possibly independent?
- When combined, signals are coherent (build in strength) whereas noise is incoherent (spreads out)

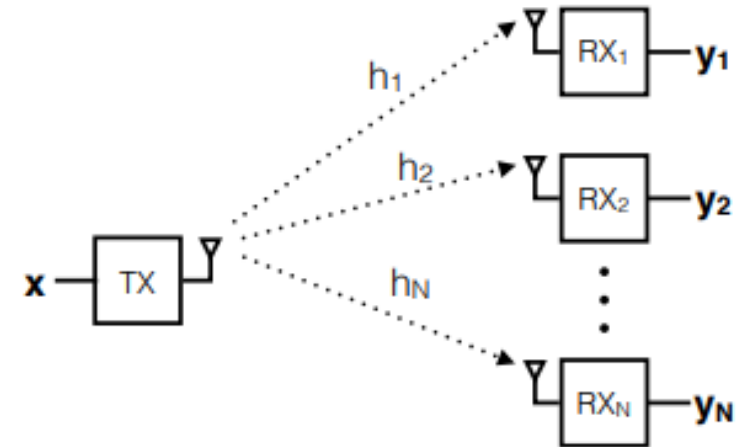

Charm uses coherent combining across gateways

- Gateways send signal data to the cloud
- The cloud can perform combining on the data and recover signals
- Challenges
 - Only send the data when it's needed
 - Tight time synchronization on the data
 - Gateway hardware changes

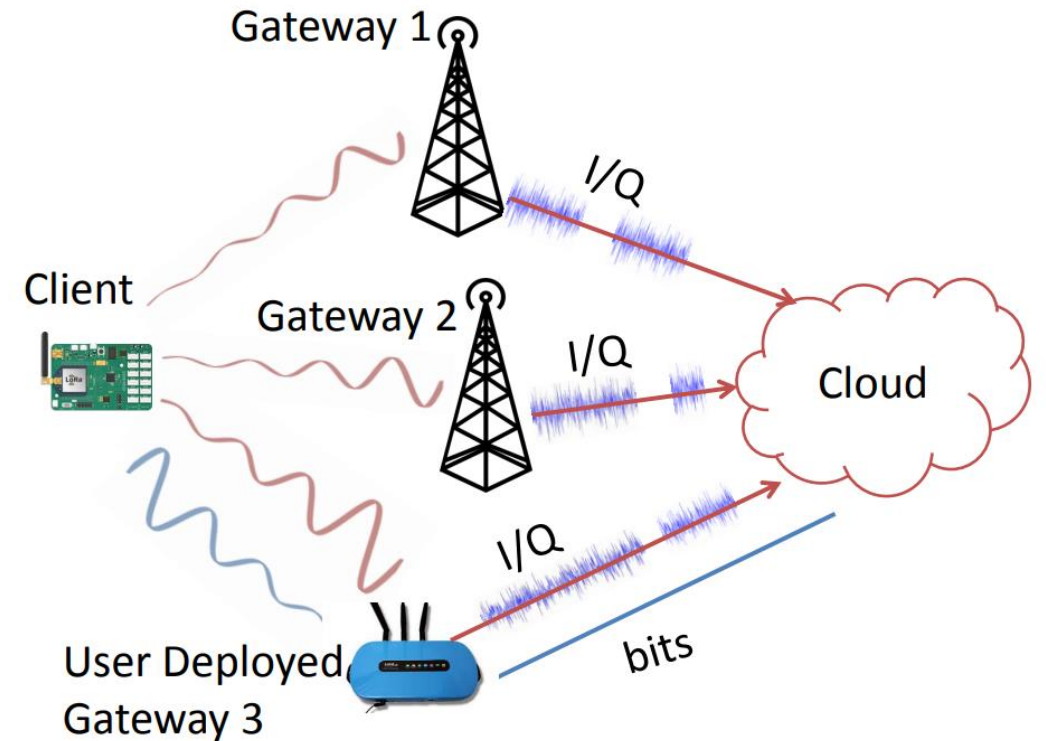

Opportunistic Packet Recovery Paper

A Cloud-Optimized Link Layer for Low-Power Wide-Area Networks

Artur Balanuta
Carnegie Mellon University
Instituto Superior Técnico
artur@cmu.edu

Swarun Kumar
Carnegie Mellon University
swarun@cmu.edu

Nuno Pereira
Carnegie Mellon University
npereira@cmu.edu

Anthony Rowe
Carnegie Mellon University
agr@ece.cmu.edu

ABSTRACT

Conventional wireless communication systems are typically designed assuming a single transmitter-receiver pair for each link. In Low-Power Wide-Area Networks (LP-WANs), this one-to-one design paradigm is often overly pessimistic in terms of link budget because client packets are frequently detected by multiple gateways

ACM Reference Format:

Artur Balanuta, Nuno Pereira, Swarun Kumar, and Anthony Rowe. 2020. A Cloud-Optimized Link Layer for Low-Power Wide-Area Networks. In *The 18th Annual International Conference on Mobile Systems, Applications, and Services (MobiSys '20)*, June 15–19, 2020, Toronto, ON, Canada. ACM, New York, NY, USA, 13 pages. <https://doi.org/10.1145/3386901.3388915>

- MobiSys 2020

Opportunistic Packet Recovery (OPR)

- Can we recover packets that have bad CRCs?
 - What if we have some information about where the interference might have occurred during the signal transmission?
 - OPR demonstrates that we can recover packets!
- Process
 1. Receive bits even for bad packets
 2. Measure RSSI for each bit along the way
 3. Look for changes in RSSI that signals interference
 4. Try different values for the effected bits until the CRC succeeds!

Detecting error bits in transmitted packets

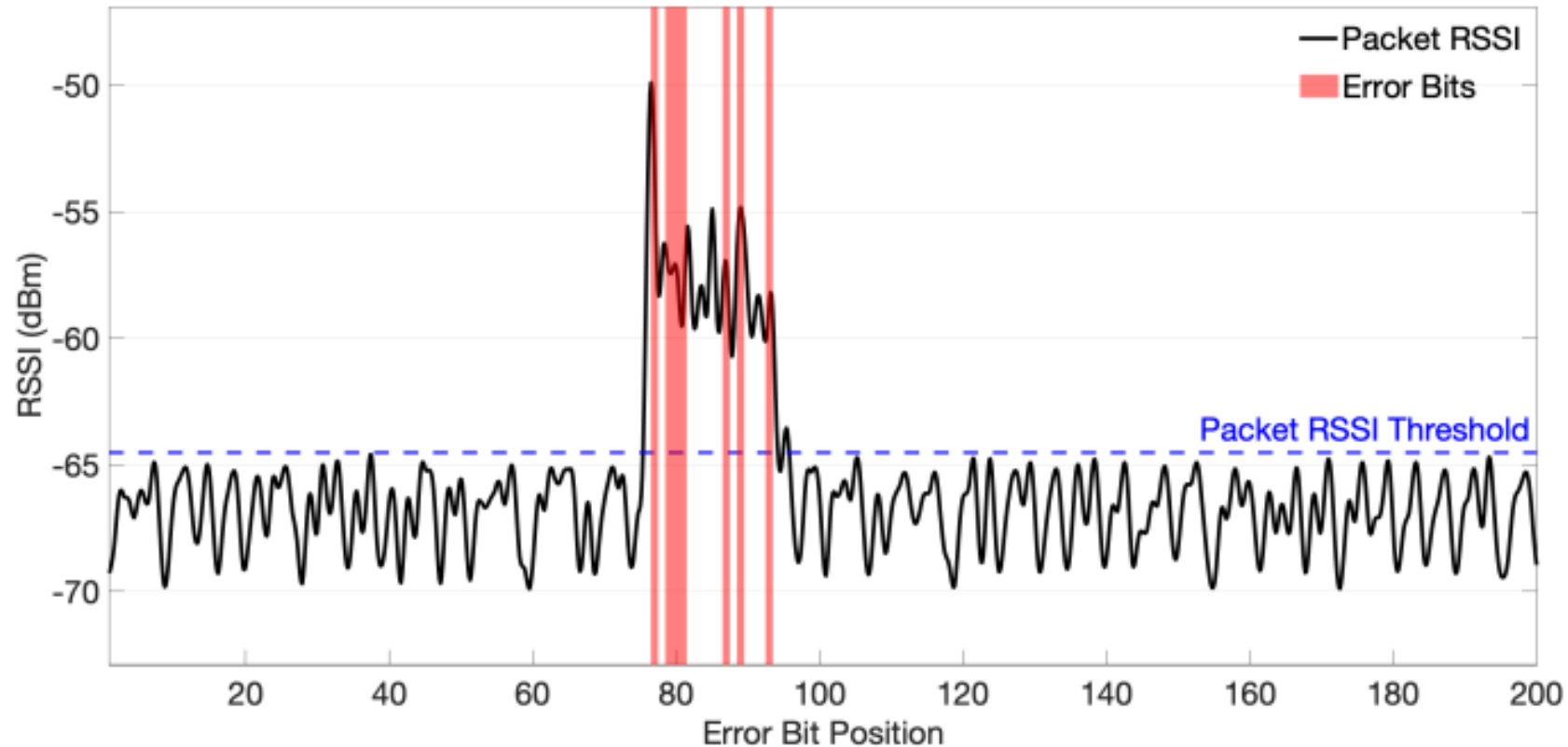

Correctly identifies 83% of the corrupted bits
with 17% false positives

Multiple gateways do even better

- If multiple gateways receive the packet, they can compare their received data
- Common bits are likely correct, while differences are likely interference

Node	Payload Hex	Bit Errors
TX	00000000000000000000000000000000	-
RX1	000000000000 2008 0000000000000000	2
RX2	000000000 2001406 0000000000000000 10	6
RX3	000000000 1002004 0000000000000000	3

OPR total design

- Bad packets are sent to the OPR Server for handling along with RSSI data
- OPR server attempts to reconstruct the packet

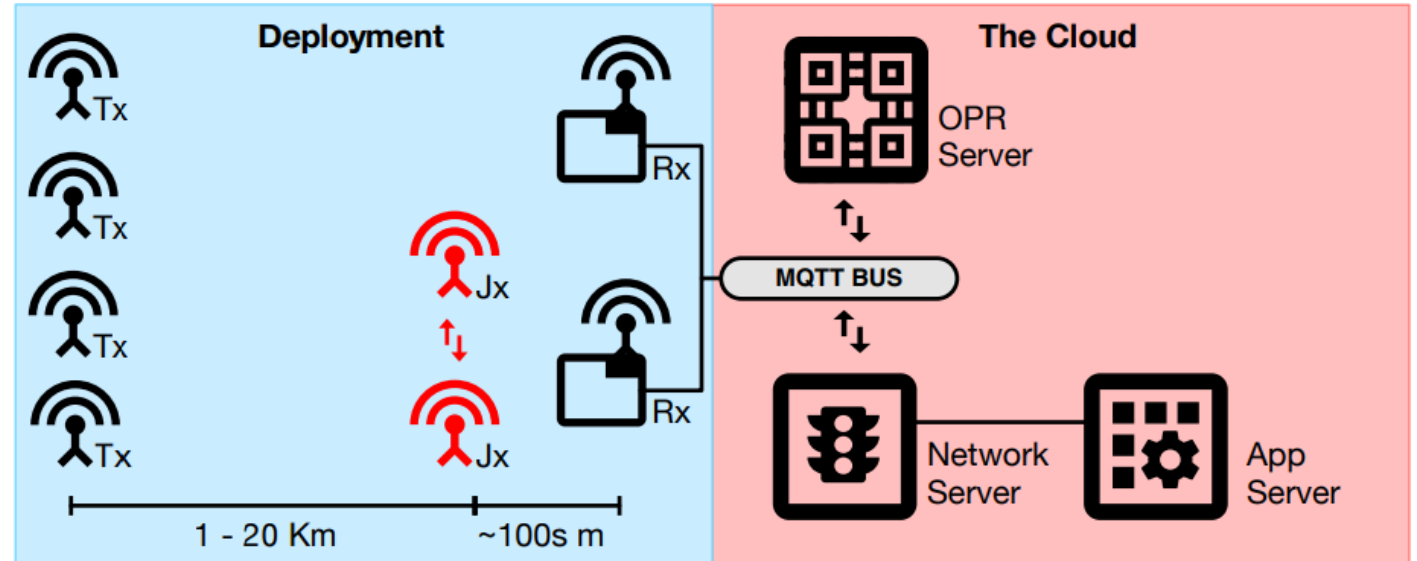

- In practice, system can correct up to 72% of CRC errors!
 - Also completes correction in time for the ACK response (within 1 second)

Break + Open Question

- What are the challenges in translating this research into real-world use?

Break + Open Question

- What are the challenges in translating this research into real-world use?
 - Improve gateway hardware: how do people buy/make it?
 - Needs a manufacturer to be interested
 - Multiple gateways are necessary
 - Not applicable to very small deployments
 - Network operators (TTN or Helium) would be good targets
 - They also have backend stuff running anyways, so adding OPR should be possible!

Outline

- LPWAN Use Cases
- Improving LoRaWAN
- **LPWAN Challenges**

Challenge for Unlicensed LPWANs Paper

Challenge: Unlicensed LPWANs Are Not Yet the Path to Ubiquitous Connectivity

Branden Ghena
University of California, Berkeley
brghena@berkeley.edu

Joshua Adkins
University of California, Berkeley
adkins@berkeley.edu

Longfei Shangguan
Microsoft Cloud & AI
longfei.shangguan@microsoft.com

Kyle Jamieson
Princeton University
kylej@cs.princeton.edu

Philip Levis
Stanford University
pal@cs.stanford.edu

Prabal Dutta
University of California, Berkeley
prabal@berkeley.edu

ABSTRACT

Low-power wide-area networks (LPWANs) are a compelling answer to the networking challenges faced by many Internet of Things devices. Their combination of low power, long range, and deployment ease has motivated a flurry of research, including exciting results on backscatter and inter-

ACM Reference Format:

Branden Ghena, Joshua Adkins, Longfei Shangguan, Kyle Jamieson, Philip Levis, and Prabal Dutta. 2019. Challenge: Unlicensed LPWANs Are Not Yet the Path to Ubiquitous Connectivity. In *The 25th Annual International Conference on Mobile Computing and Networking (MobiCom'19)*, October 21–25, 2019, Los Cabos, Mexico. ACM, New York, NY, USA, 12 pages. <https://doi.org/10.1145/>

- MobiCom 2019

Two major categories of low-power, wide-area network protocols

- **Unlicensed LPWANs**

- Sigfox, LoRaWAN, etc.
- Unlicensed band, 915 MHz (US)
- Managed or user deployable

- **Cellular IoT**

- LTE-M and NB-IoT
- Licensed cellular bands
- Managed networks
- Rolled out US-wide

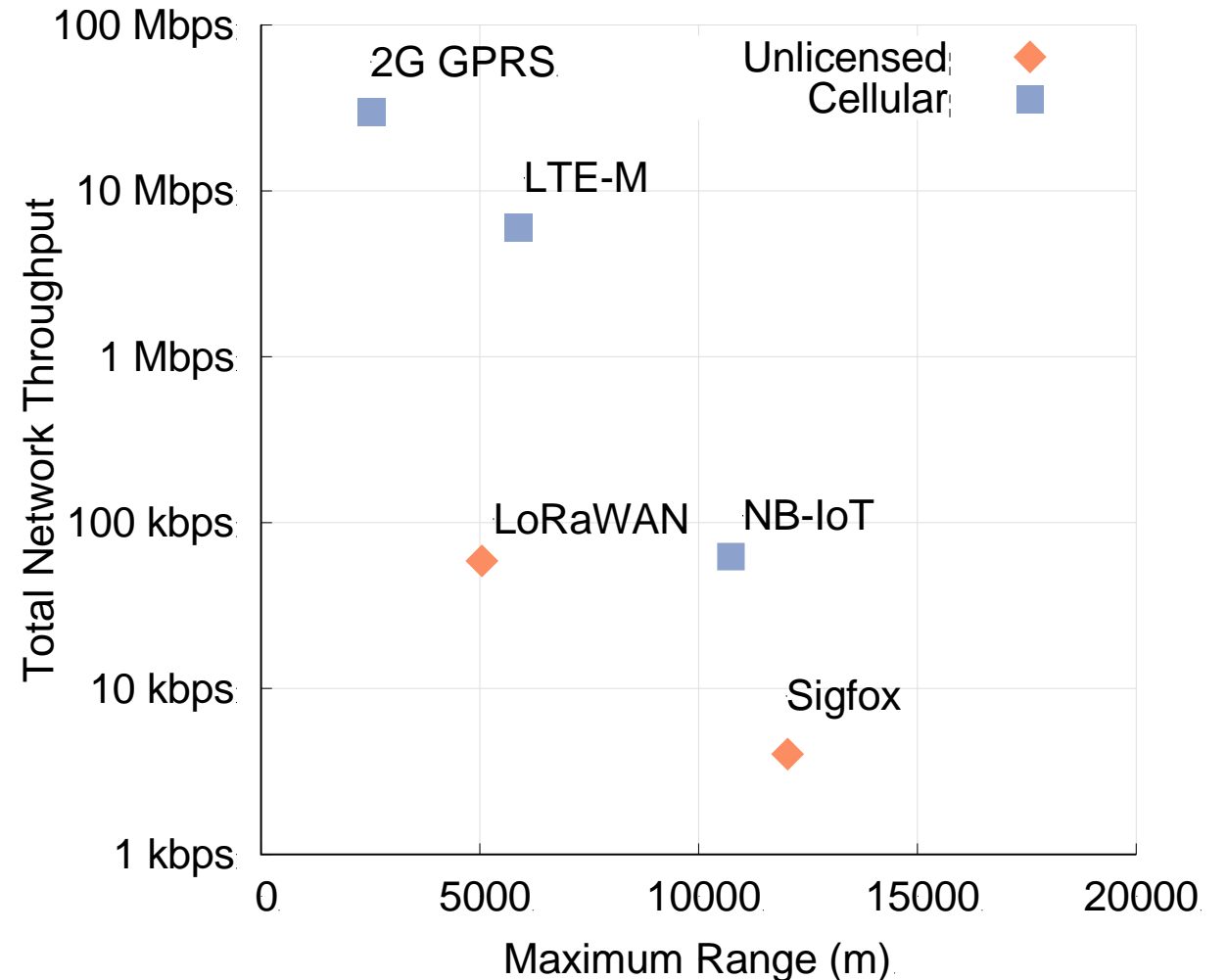

Do novel networks meet application needs?

- How do we compare varied requirements and capabilities?
 - Networks have throughput per gateway and range of gateway.
 - Applications have throughput per device and deployment area.
- Each gateway must support throughput for all devices in its coverage area.
 - Deployment areas are often wider than a single gateway's range.
- Solution: compare the density of communication.
 - Data communication rate per unit area.

New metric for wide-area communication.

Our proposed metric: **bit flux**

- $bit\ flux = \frac{network\ throughput}{coverage\ area}$
- Units: bit per hour / m²
- First suggested by Mark Weiser

Branden Ghena, et al. "Challenge: Unlicensed LPWANs Are Not Yet the Path to Ubiquitous Connectivity." *MobiCom'19*

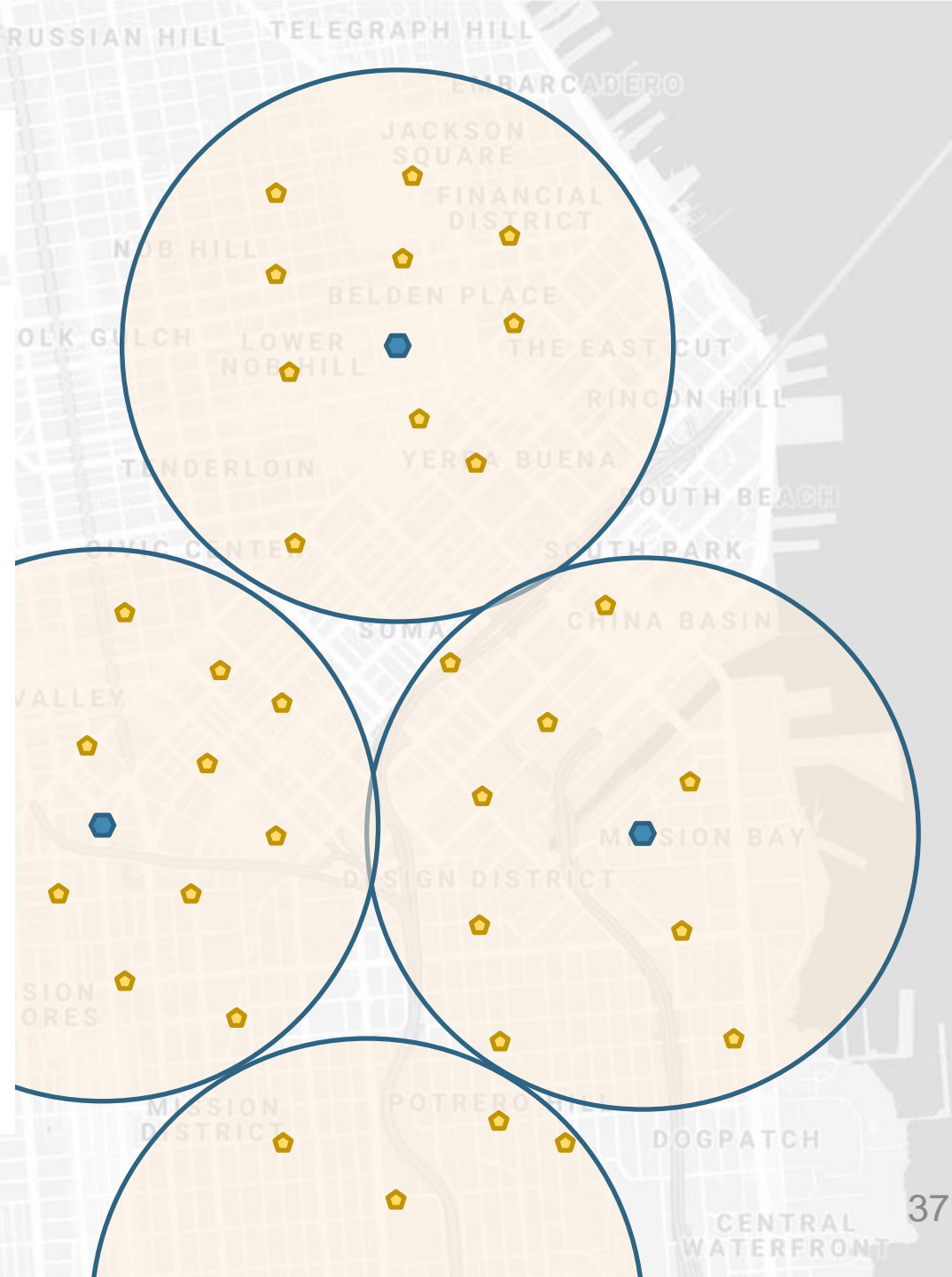

Bit flux can measure application needs.

For an application:

$$\textit{bit flux} = \frac{\sum \textit{each device's uplink}}{\textit{deployment area}}$$

- Assumes a relatively homogeneous distribution.

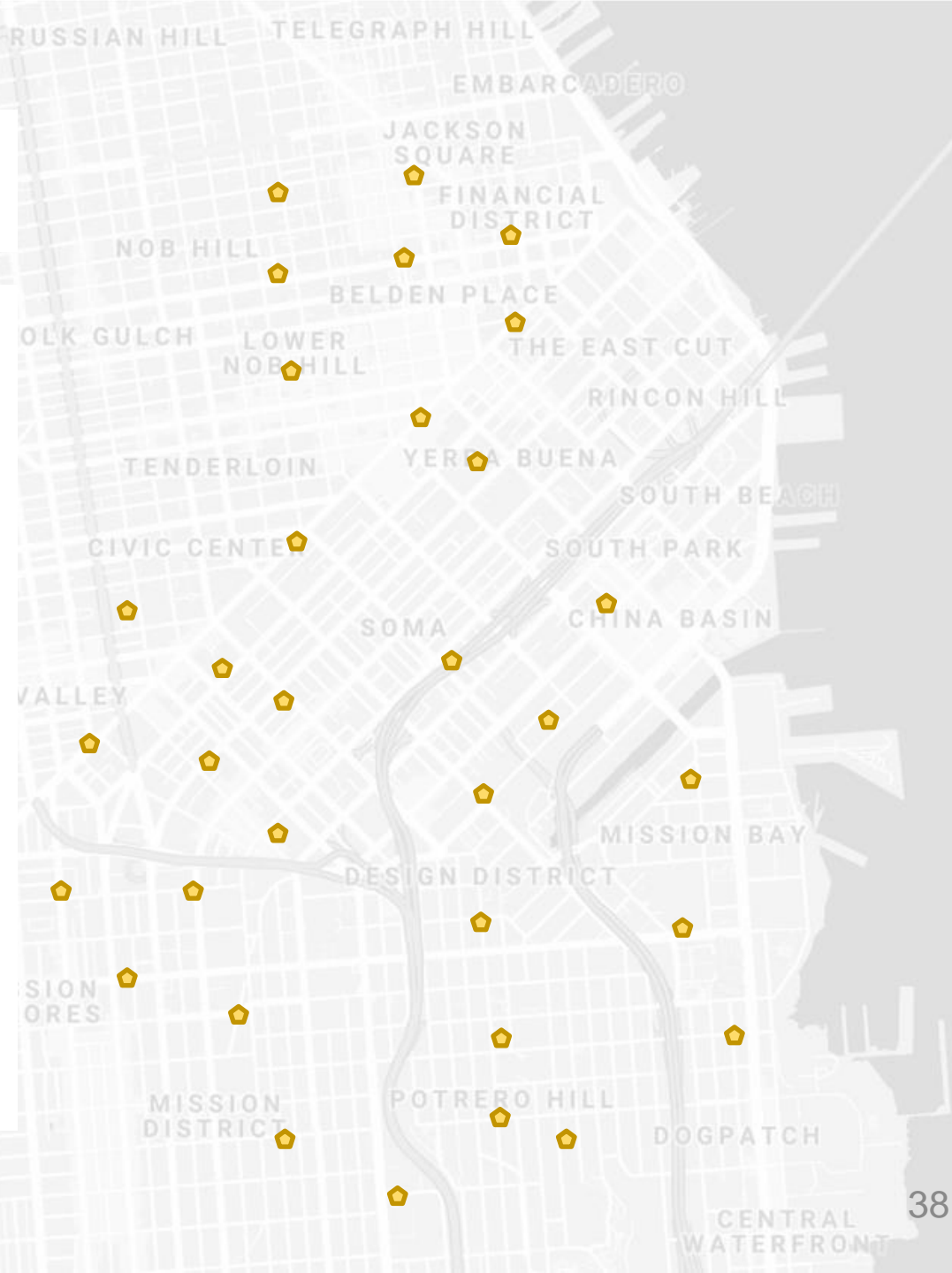

Bit flux can measure network capabilities.

For a network:

$$\textit{bit flux} = \frac{\textit{gateway goodput}}{\textit{gateway coverage area}}$$

- Assumes a non-overlapping deployment of gateways.
- Note that bit flux alone ignores the total number of gateways required.

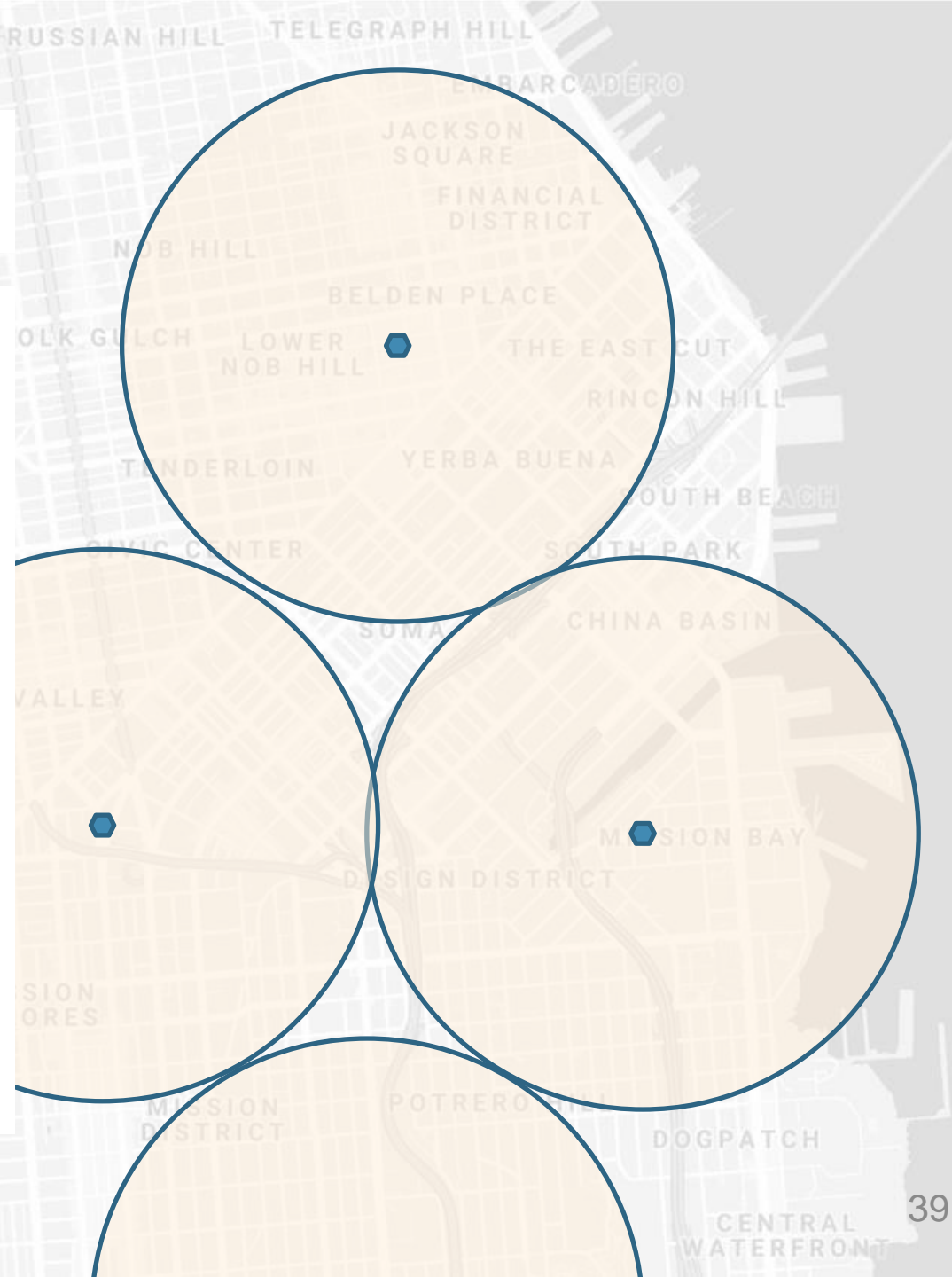

Bit flux accounts for spatial reuse.

- Reducing coverage area and deploying additional gateways improves capacity.

- $bit\ flux \uparrow = \frac{gateway\ goodput}{coverage\ area\downarrow}$

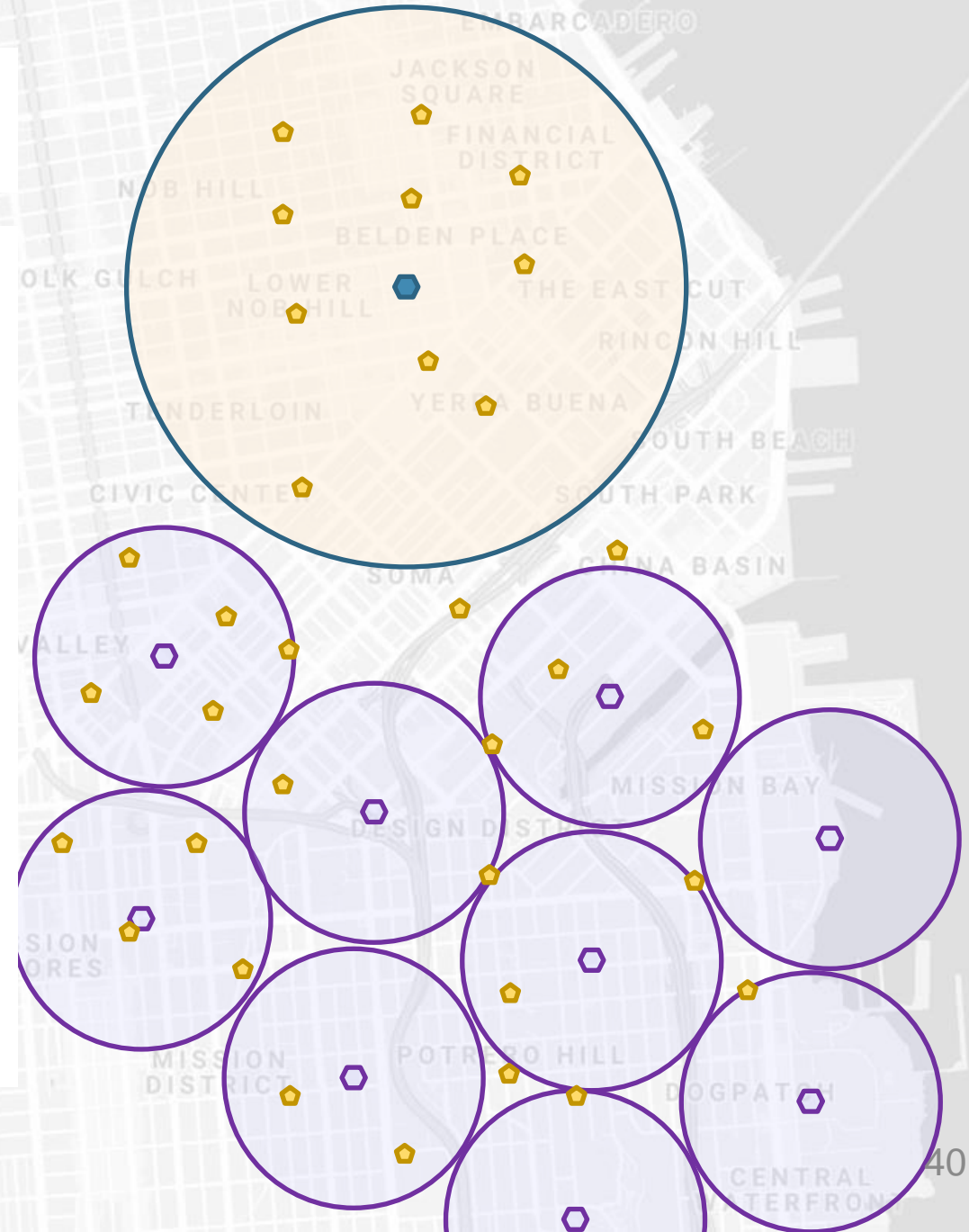

Bit flux measurement for LoRaWAN.

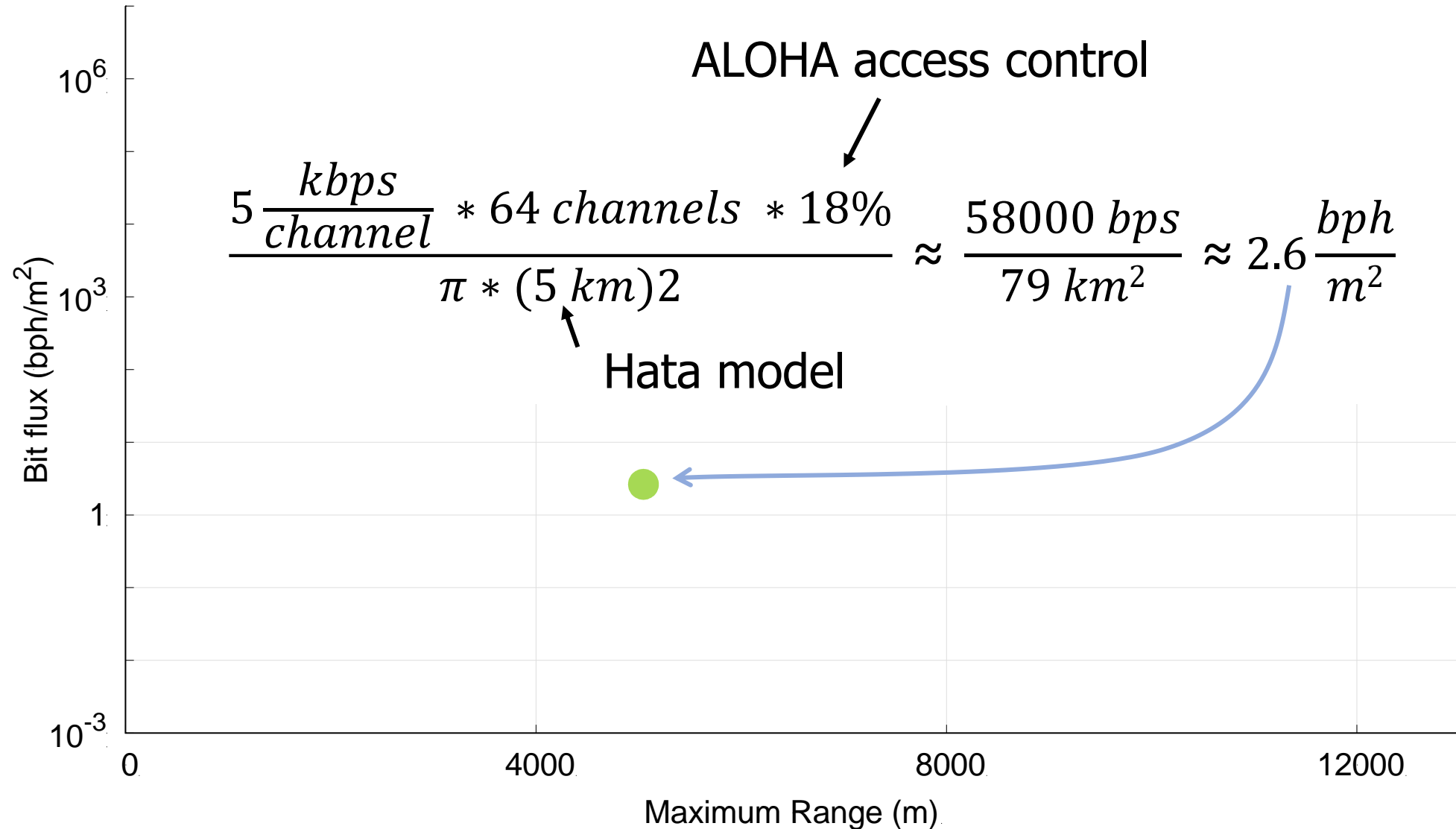

Networks differ in capability by orders of magnitude.

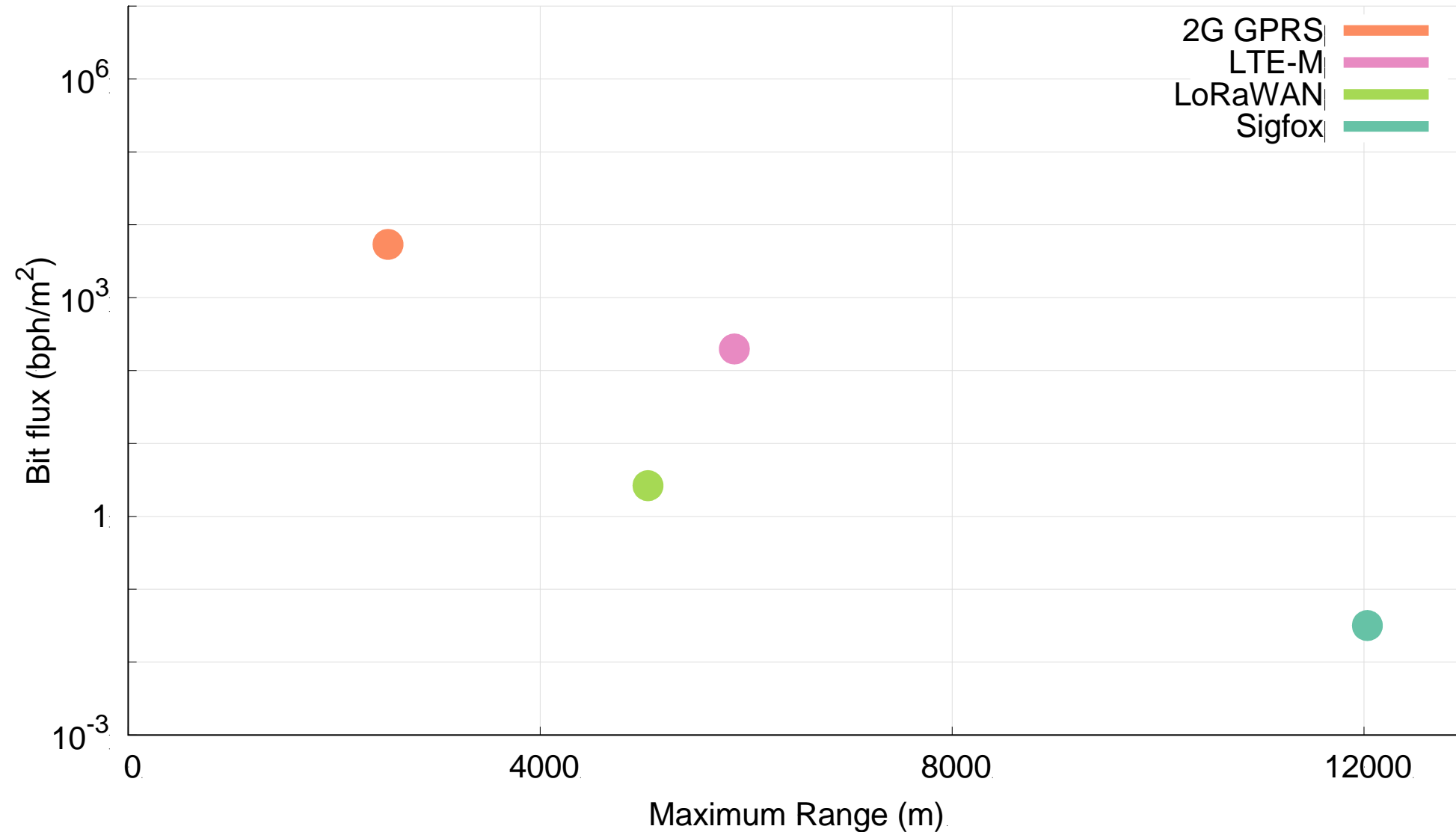

Range reduction results in a bit flux curve for each network.

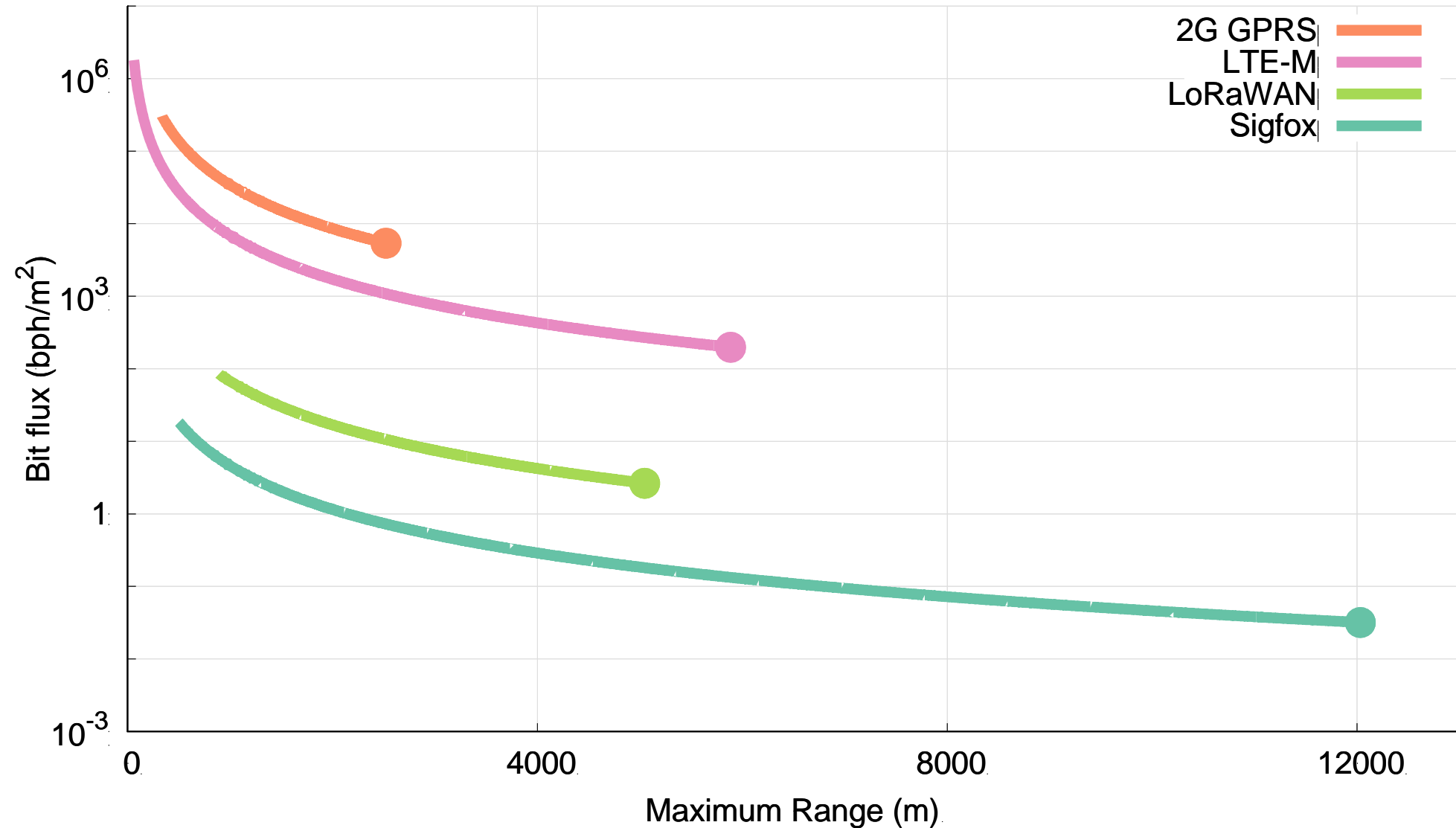

Let's compare network capabilities to a real-world application.

Smart household electric meters.

- ~250 bytes of data every 4 hours
- ~370000 electric customers in San Francisco



$$\frac{250 \text{ bytes}}{4 \text{ hours}} * 370000 \text{ devices} \approx \frac{51000 \text{ bps}}{120 \text{ km}^2} \approx 1.5 \frac{\text{bph}}{\text{m}^2}$$

Bitflux for various applications

- See paper for full details on each application
- Creates a comparison point between applications and networks!

Application	Single Location Throughput (<i>bps</i>)	Single Location Radius (<i>m</i>)	Pervasive Bit Flux ($\frac{bph}{m^2}$)
Zebranet [63]	53	75	0
Trash can monitoring [4]	0.38	370	0.003
Hospital clinic [6]	11	20	0.02
Volcano monitoring [61]	520	1,500	0.2
CitySee [30, 64]	20,400	5,700	1
Electricity metering [12, 39]	51,389	6,180	1.5
Habitat monitoring [29]	10	10	9
H1N1 [22]	18,000	60	43
IMT-2020 [18, 19]	35,556	564	128
Macroscope [52]	12	4	221
GreenOrbs [33, 64]	5,600	80	1,000

<https://brandenghena.com/projects/lpwan/ghena19lpwans.pdf>

All networks are capable of meeting the data needs of electricity metering.

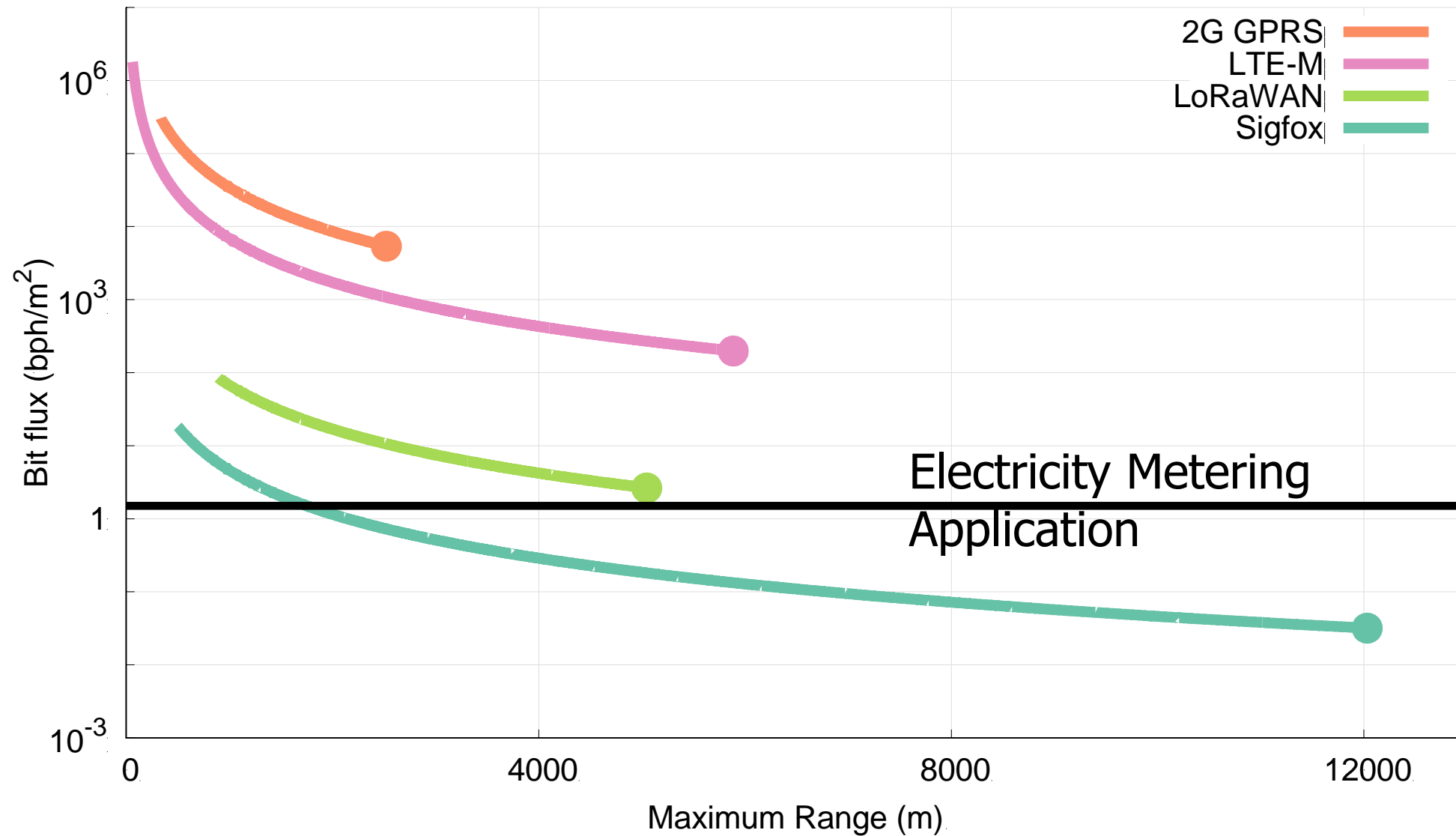

Unlicensed LPWANs lag behind Cellular IoT in ability to support applications.

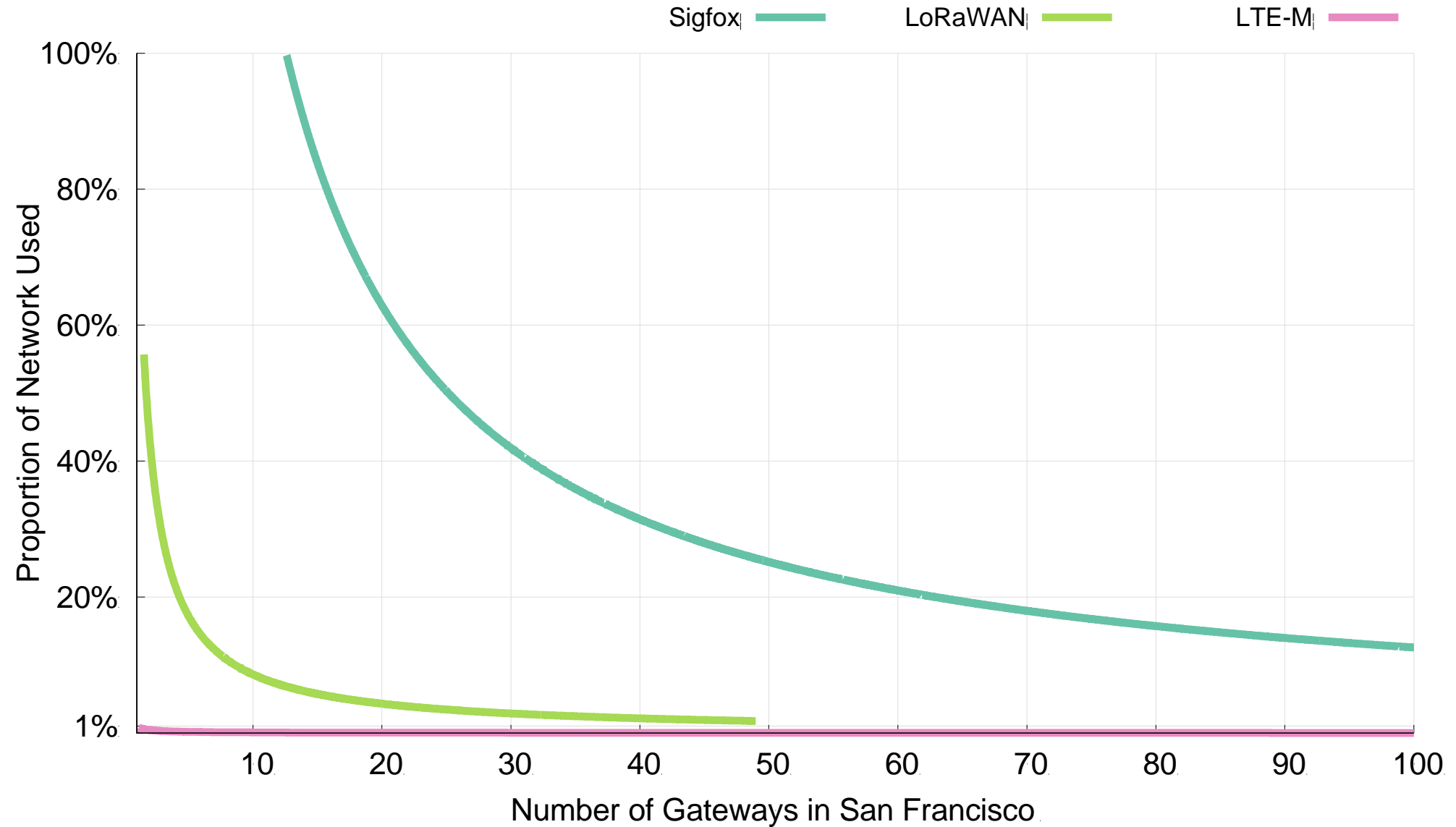

2G < 0.03% utilized 47

Sigfox requires range reduction to meet application needs.

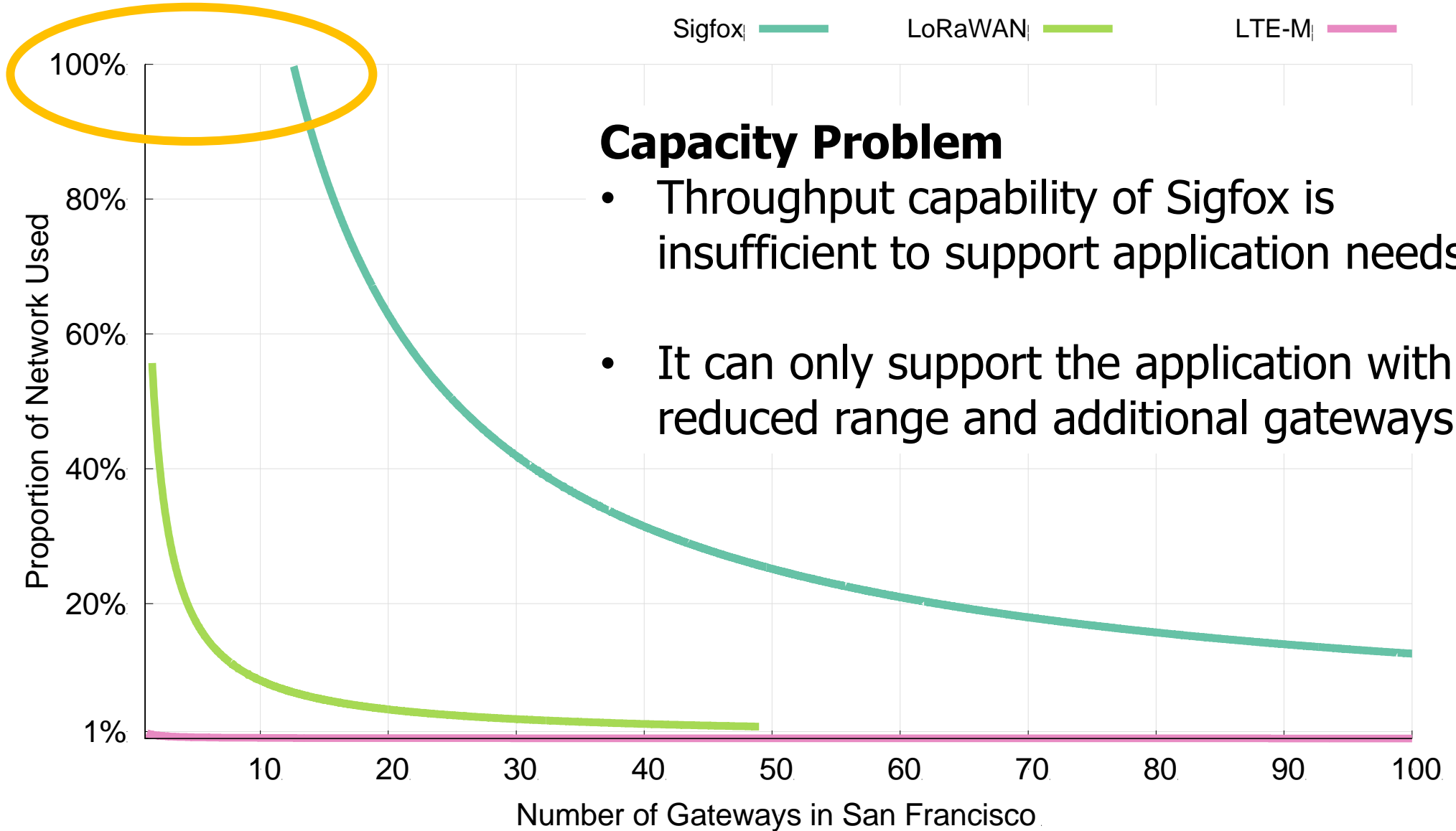

Capacity Problem

- Throughput capability of Sigfox is insufficient to support application needs
- It can only support the application with reduced range and additional gateways

Capacity solutions are relatively straightforward.

- Better access control mechanisms. Explore CSMA?
- Recover simultaneous transmissions (Choir and Charm).
- Increase bandwidth (TV white spaces).

- All likely come at the cost of increased energy usage...
 - Results in a protocol that looks pretty similar to cellular...

Adwait Dongare, et al. "Charm: exploiting geographical diversity through coherent combining in low-power wide-area networks." *IPSN'18*

Rashad Eleteby, et al. "Empowering low-power wide area networks in urban settings." *SIGCOMM'17*

Abusayeed Saifullah, et al. "SNOW: Sensor network over white spaces." *SenSys'16*

LoRaWAN devotes most of its network capacity to a single application.

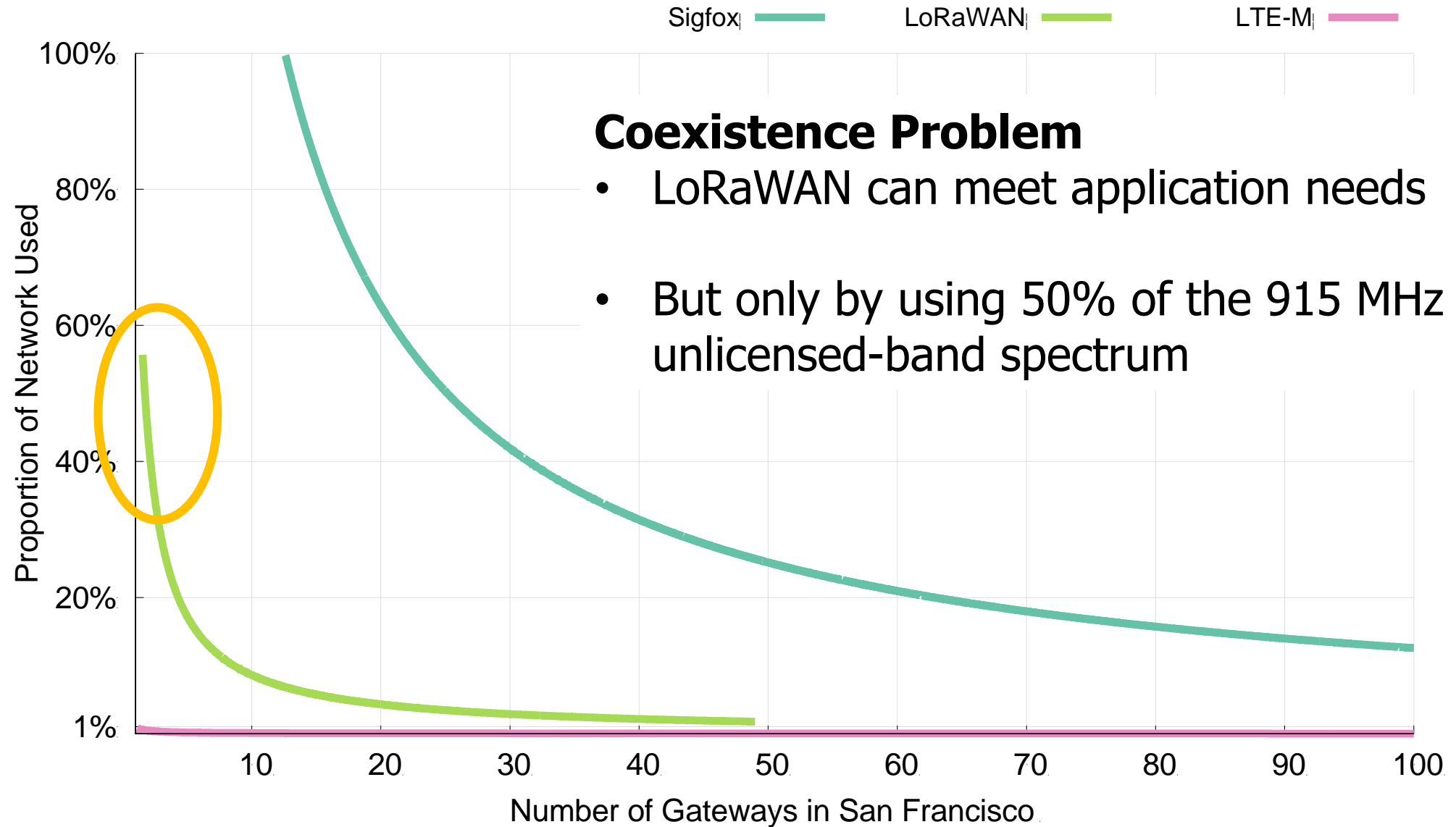

Coexistence Problem

- LoRaWAN can meet application needs
- But only by using 50% of the 915 MHz unlicensed-band spectrum

Coexistence is inevitable in urban areas.

- Urban environments and long range lead to many overlapping deployed networks.
- Capacity problems worsen coexistence by devoting more bandwidth to one application.
- It's not just electricity metering...

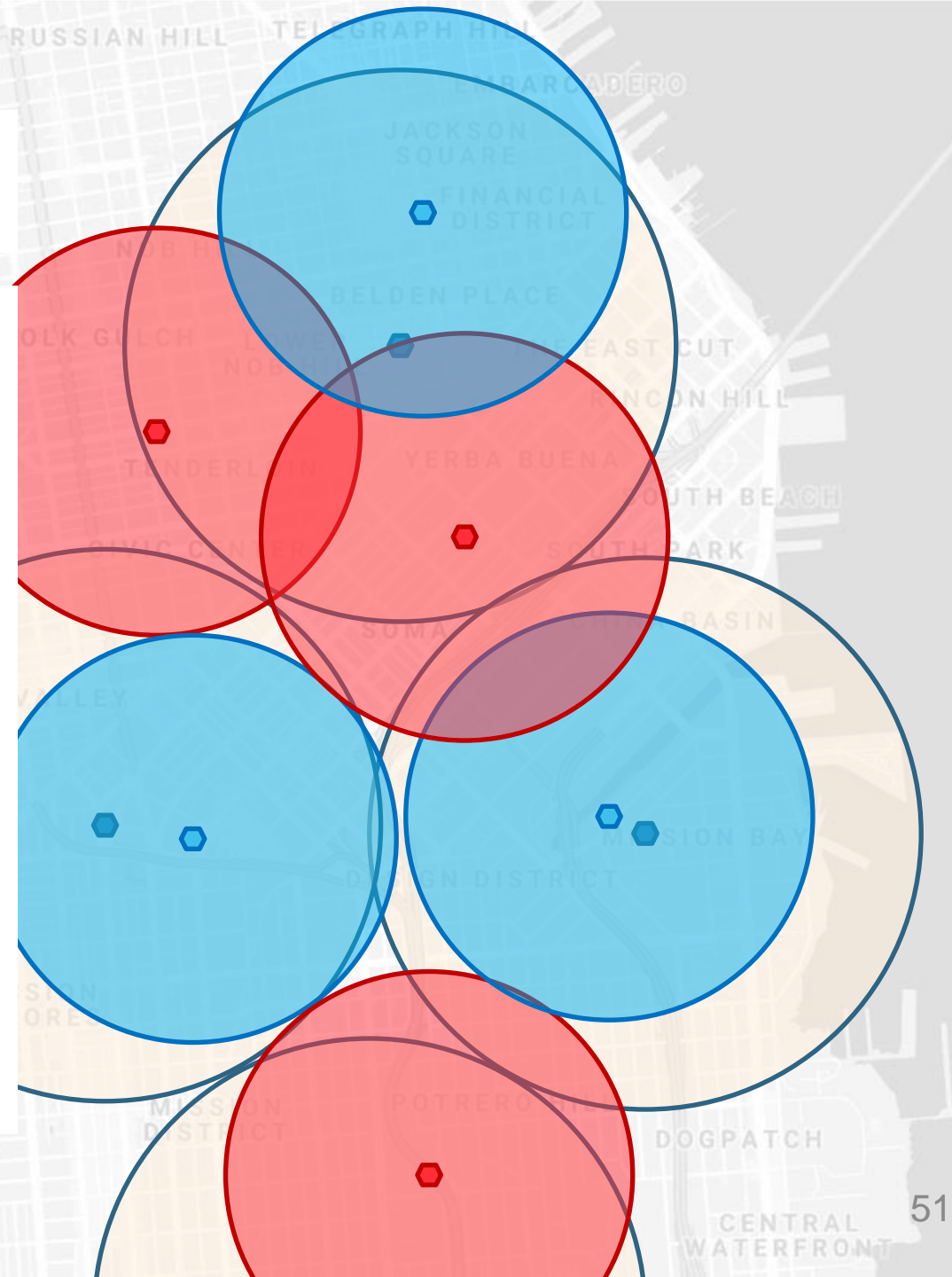

Coexistence in unlicensed bands is a more difficult problem.

- No methods for inter-network negotiation so far.
- Without buy-in from most deployments, all access control becomes uncoordinated.

- **Cellular IoT does not have this problem**

Cellular may dominate future deployments.

- LTE-M and NB-IoT are now deployed in the US (and worldwide).
- Licensed bandwidth avoids the coexistence problem.
- Cellular may solve many applications but is not a perfect solution.
 - Still has higher energy and monetary costs for use.
 - Also limited to where service is already available.

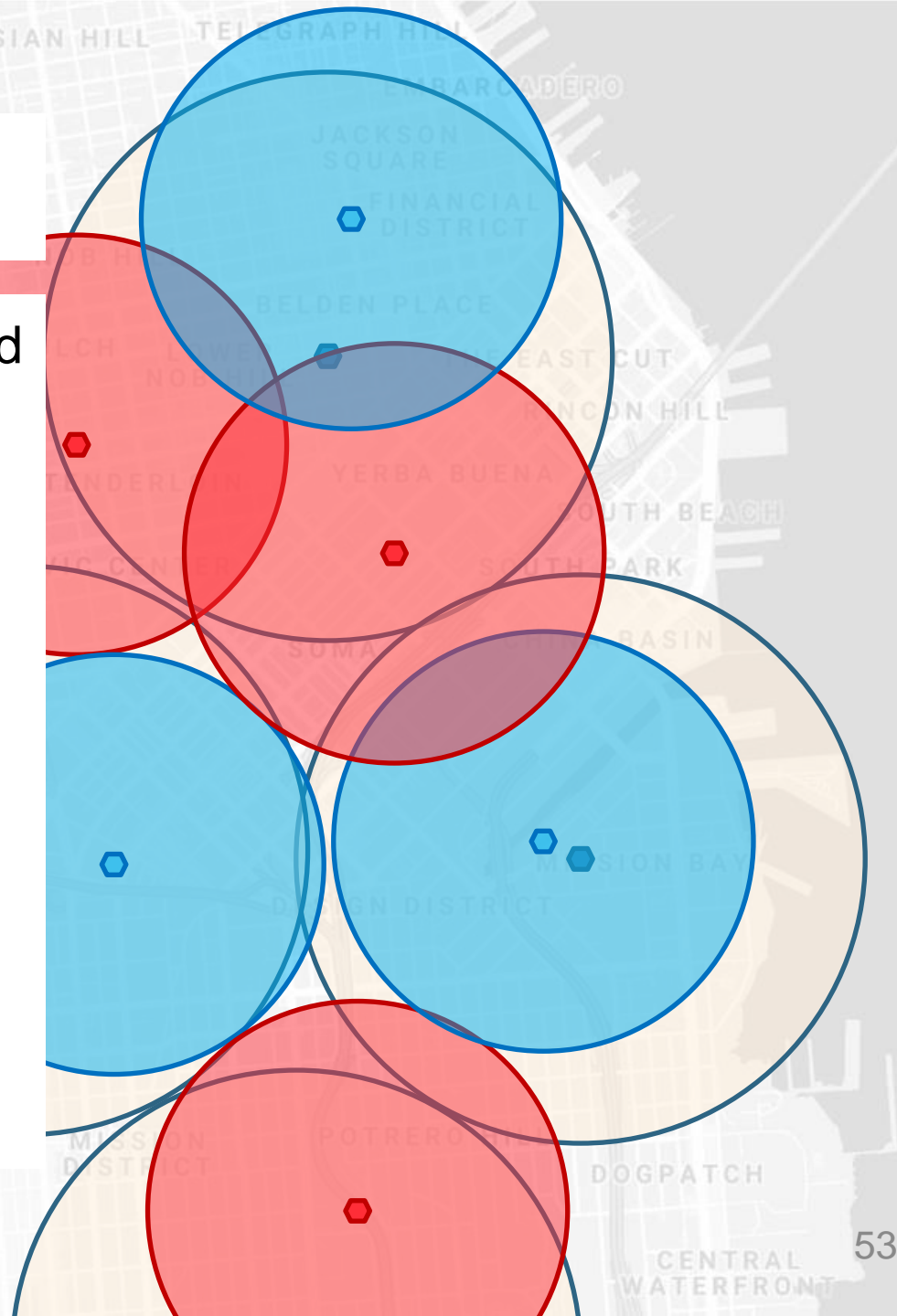

Unlicensed LPWANs are still useful for some scenarios.

- Controlled or unoccupied regions have reduced coexistence concerns.
 - Industrial factories, farms, parks and forests.
- Unlicensed networks are very exciting for research.
 - Anyone can deploy a network wherever they want.
 - Much easier to explore protocol modifications and new technologies.
- Research suffers without real-world applications.
 - Problem areas are strong recommendations for new research.
 - New research is only useful if they will have real-world impacts.

Implications – Low-Power Wide-Area Networks.

- Existing unlicensed LPWANs face significant challenges in supporting urban applications.
 - Best suited for industrial or agricultural uses in controlled environments.
- Research directions for unlicensed LPWANs:
 - improve network capacity,
 - and enable coexistence.
- Cellular IoT networks (LTE-M and NB-IoT) are positioned to solve the needs of city-scale sensing.
 - If the money and energy costs are there.

Outline

- LPWAN Use Cases
- Improving LoRaWAN
- LPWAN Challenges