

Lecture 06

Timers

CE346 – Microprocessor System Design
Branden Ghena – Fall 2023

Some slides borrowed from:
Josiah Hester (Northwestern), Prabal Dutta (UC Berkeley)

Administrivia

- Last chance for Lab1 checkoffs 7:00-8:30 today
 - Looks like ~4 groups to go, so it shouldn't be too bad
- Don't forget to answer the postlab questions on Gradescope
 - You and your partner can work on them together, but submit separately
 - Due by Tuesday this week only
- Lab2 tomorrow! Virtual Timer Lab
- Project proposals due next week Thursday!
 - Be sure to find a group. Fill out the survey if you want to find someone!

Today's Goals

- Understand the role of clocks in a microcontroller
- Explore functionality of various timer peripherals on the Microbit

Outline

- **Clocks**
- Timers
- Virtualizing Resources
- Real-Time Counter
- Watchdog

What are clocks?

- Clock signals, in the microcontroller context, are oscillating square wave signals used to switch transistors and latch inputs

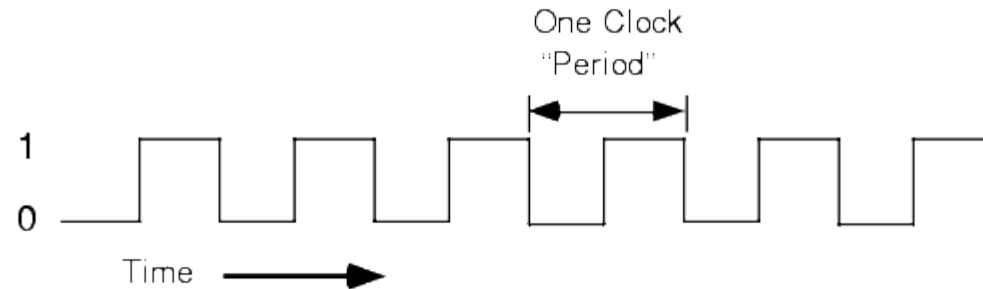

- A clock **MUST** be running for (almost) anything on a microcontroller to function (processor and peripherals)
 - Exceptions:
 - Low-power input interrupts
 - GPIOTE port interrupt, Analog LPCOMP interrupt, NFC sense interrupt, USB power interrupt
 - Reset signal

Generating clocks

- External crystal oscillator
 - Creates clock signal
 - Chunk of quartz
 - Behaves like RLC circuit but uses less energy
- Internal mechanisms
 - RC oscillator
 - Creates clock signal
 - Less accurate and higher energy than crystal
 - Phase-Locked Loop (PLL)
 - Multiply input to create new higher frequency clocks

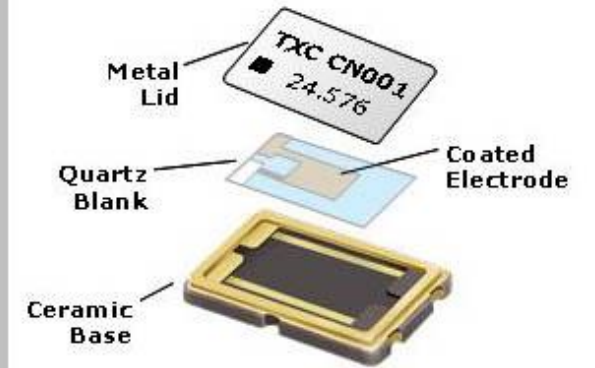

(Fig.7) (a) Metal can type resonator
(b) Ceramic SMD type resonator
(c) Symbol of crystal unit

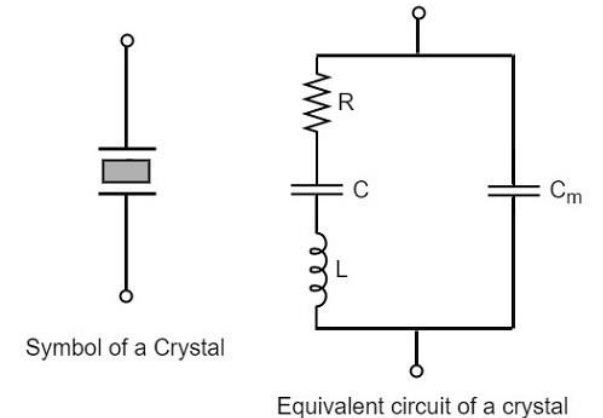
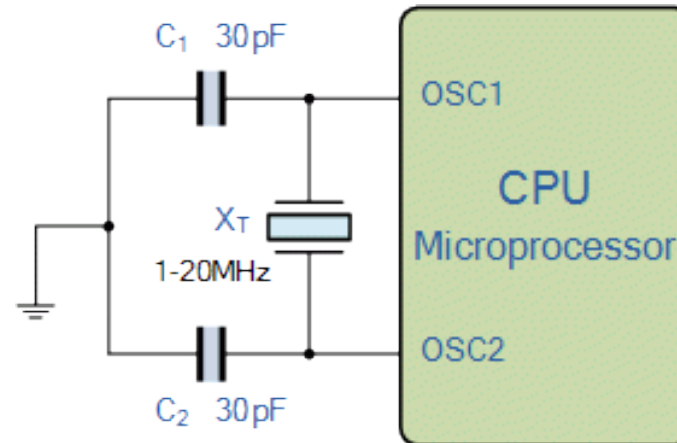
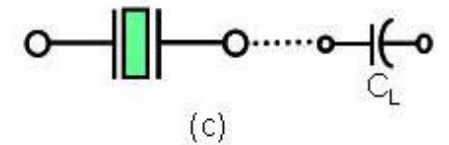

Microbit crystal for nRF52833



Clocks and energy

- Fundamental tradeoff
 - Faster clock gets things done faster but uses more energy
 - Slower clock uses less energy but gets things done slower
 - Which to use depends on the situation
 - CPU bound: faster clock, IO bound: slower clock

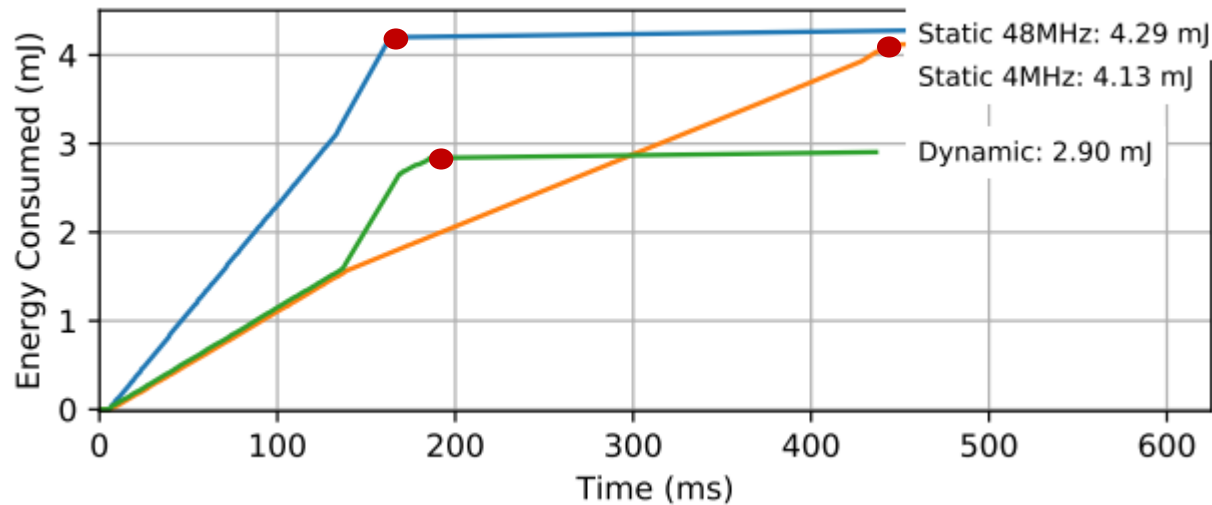

Example of clock selection for a mixed load (part IO, part CPU)

Energy consumed becomes a horizontal line when the task is completed

Controlling clocks

- Some microcontrollers provide extremely fine-grained control over clocks
 - Really complicated section of code to get working
 - Many combinations are invalid
 - Manually enable/disable clocks as needed
- nRF52 instead gives almost no control but is easier to use
 - One 64-MHz clock for processor
 - Multiple peripheral clocks, but (most) peripherals are hardwired to one
 - 16 MHz for almost all peripherals (PDM and I2S are 32 MHz)
 - Low-frequency 32 kHz clock for low-power peripherals
 - Automatically enables/disables clocks

nRF52833 clocks

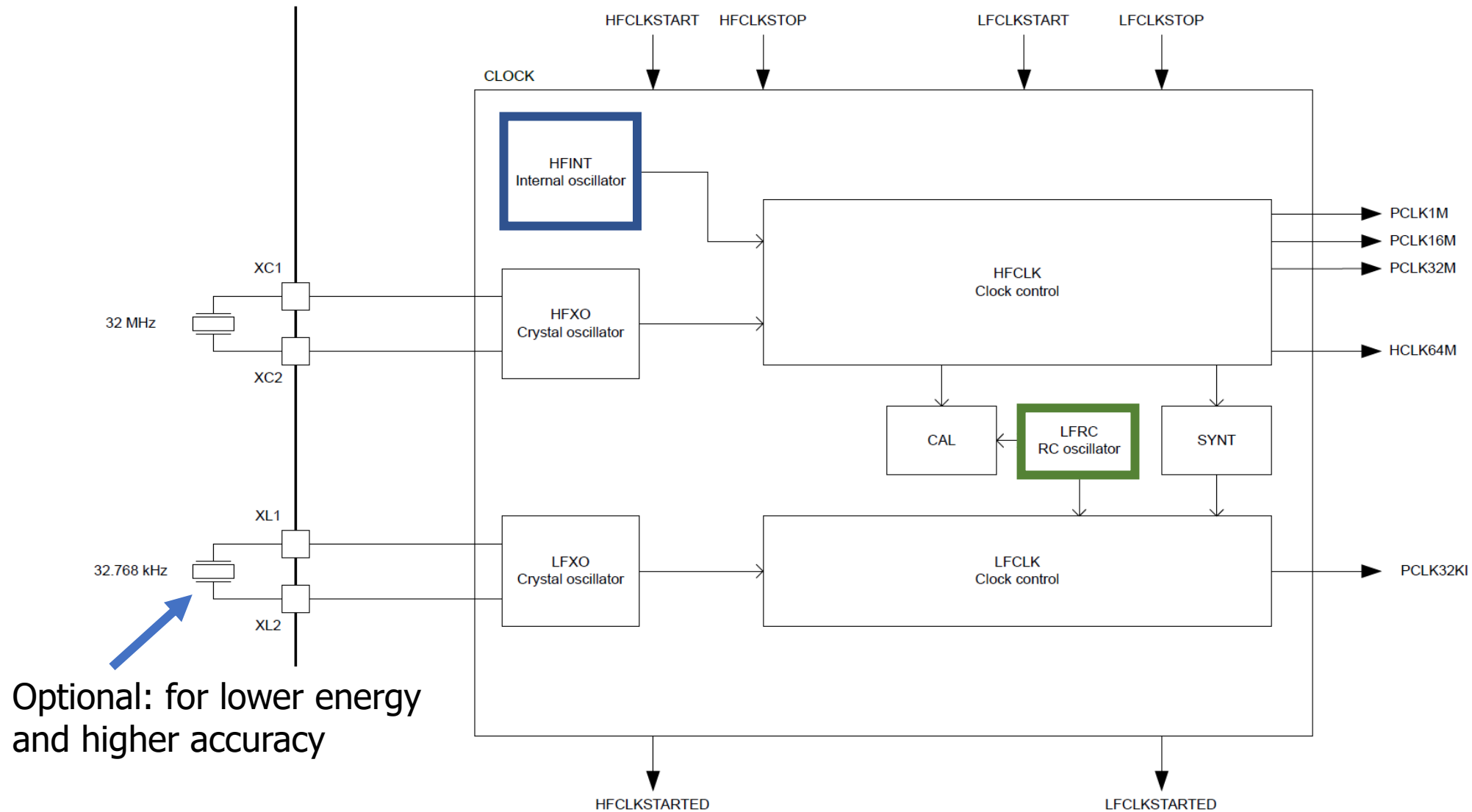

Electrical characteristics

- Active power of clocks

- 32 kHz crystal run current: 0.23 μA
- 32 kHz RC oscillator run current: 0.70 μA
- 32 MHz crystal average run current: 300-700.00 μA
- 32 MHz standby current: 110.00 μA

- Startup time for external crystals

- 32 kHz crystal: 250-500 ms (milliseconds!!!)
- 32 MHz crystal: 60-200 μs
- Beware: switching can lead to delays and instability
 - nRF52 uses RC oscillator while crystal is not yet ready

Outline

- Clocks
- **Timers**
- Virtualizing Resources
- Real-Time Counter
- Watchdog

Timer peripherals

- Common need for embedded systems: sense of time
 - Start this behavior after a certain amount of time
 - Stop this behavior after a certain amount of time
 - Measure how much time passed between two events
- Timer peripherals
 - Input is one of the system clocks
 - Counts up a register at each clock tick
 - Looking at register at start and end can give real-world duration
 - Compare to saved value and trigger interrupt on match
 - Allows interrupts to be scheduled in the future

Discussion

- What is the finest granularity you might need from a timer?
 - Give an example of the use case
- What is the longest duration you might need from a timer?
 - Give an example of the use case

Discussion

- What is the finest granularity you might need from a timer?
 - Give an example of the use case
- What is the longest duration you might need from a timer?
 - Give an example of the use case
- Concern: high granularity for long durations require MANY bits
 - We often optimize for one of the other

Timer peripheral on nRF52833

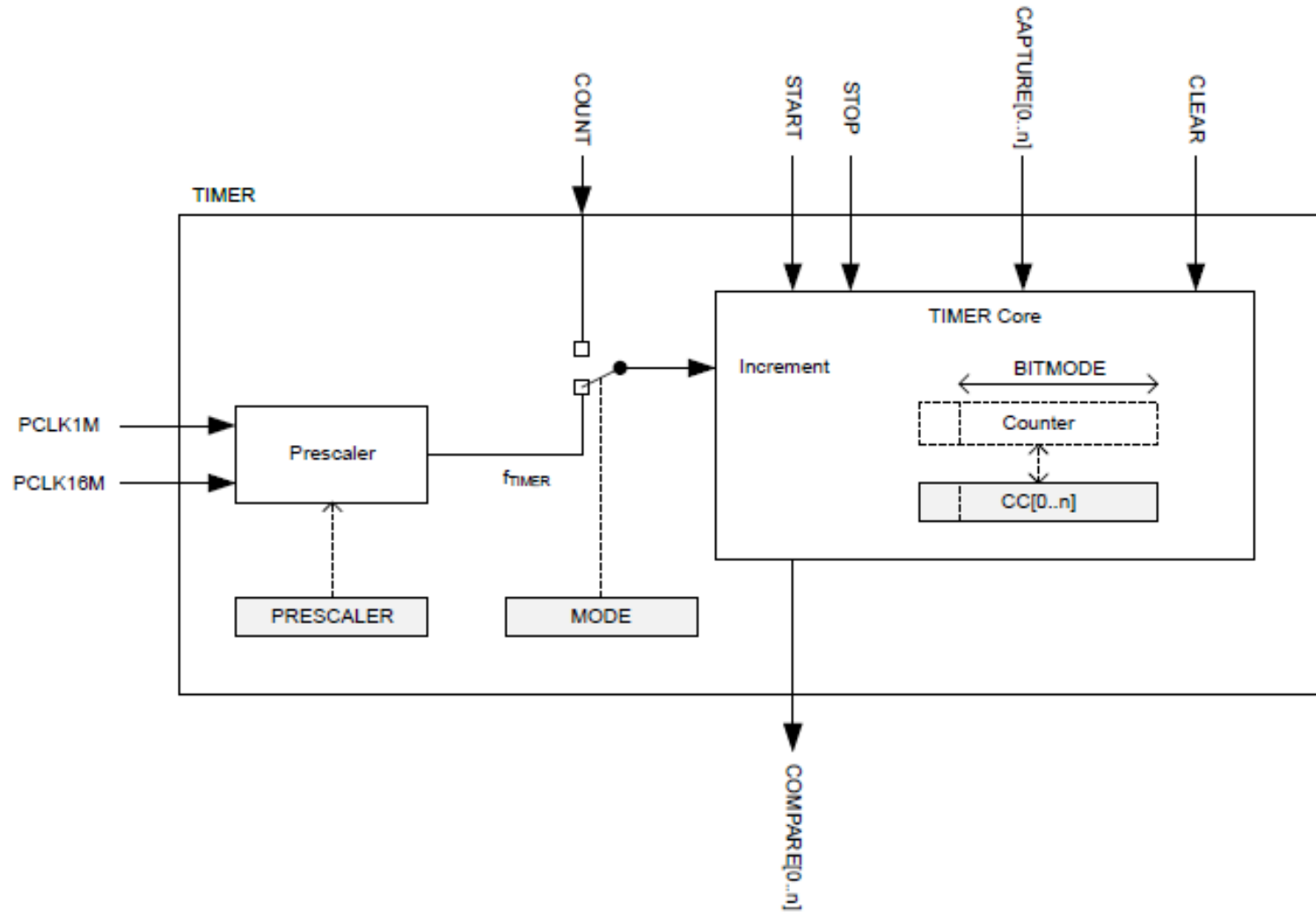

Input and Prescaler

$$f_{\text{TIMER}} = \frac{16 \text{ MHz}}{2^{\text{PRESCALER}}}$$

- Prescaler is a 4-bit number
 - Possible timer input clocks: 16 MHz – 488 Hz
- Ticks counted with (up to) 32-bit internal Counter:
 - Minimum
 - **268 seconds** until overflow
 - **62.5 ns** per tick
 - Maximum
 - **101 days** until overflow
 - **2.04 ms** per tick

Alternate input source for counter mode

- Counter mode works with non-timer inputs
 - E.g. GPIO input event
- Count anything!

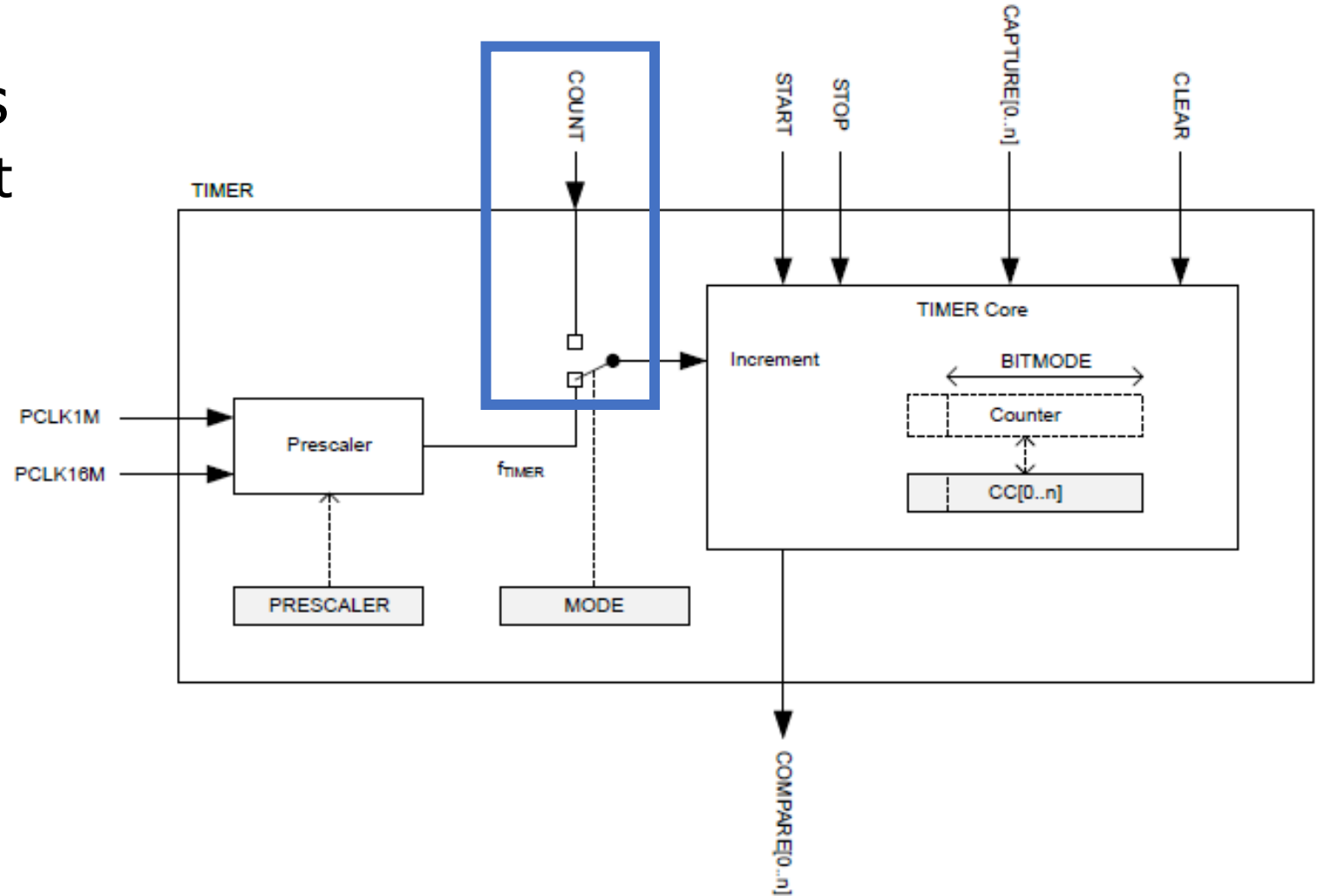

Capture/Compare registers (CC)

- 32-bit storage registers (each timer has multiple)
 - Uses: capturing or comparing
- On Capture[n] event
 - Internal Counter value copied to CC[n]
 - Then you can read the former Counter value from CC[n]
- Capture used to measure durations of events
 - Capture can be triggered by software or by Events from other peripherals
 - Multiple registers to measure multi-part events

Comparing with CC registers

- When internal Counter value equals a CC register
 - Corresponding Compare[n] event is triggered
 - Can trigger interrupts
- Usually written to in advance to start/stop behavior
 - Toggle LED every second
 - Sample sensor every five minutes
 - Refresh LED matrix every 1/60 seconds

The nRF52833 has multiple Timer instances

6.28.5 Registers

Base address	Peripheral	Instance	Description	Configuration
0x40008000	TIMER	TIMER0	Timer 0	This timer instance has 4 CC registers (CC[0..3])
0x40009000	TIMER	TIMER1	Timer 1	This timer instance has 4 CC registers (CC[0..3])
0x4000A000	TIMER	TIMER2	Timer 2	This timer instance has 4 CC registers (CC[0..3])
0x4001A000	TIMER	TIMER3	Timer 3	This timer instance has 6 CC registers (CC[0..5])
0x4001B000	TIMER	TIMER4	Timer 4	This timer instance has 6 CC registers (CC[0..5])

Bonus concept: shorts

- In a peripheral: **Tasks** are inputs and **Events** are outputs
- Shorts connect an Event to a Task within a peripheral
 - Tasks and Events idea is fairly nRF specific

- Timer shorts

- Connect Compare[n] to Clear
- Connect Compare[n] to Stop

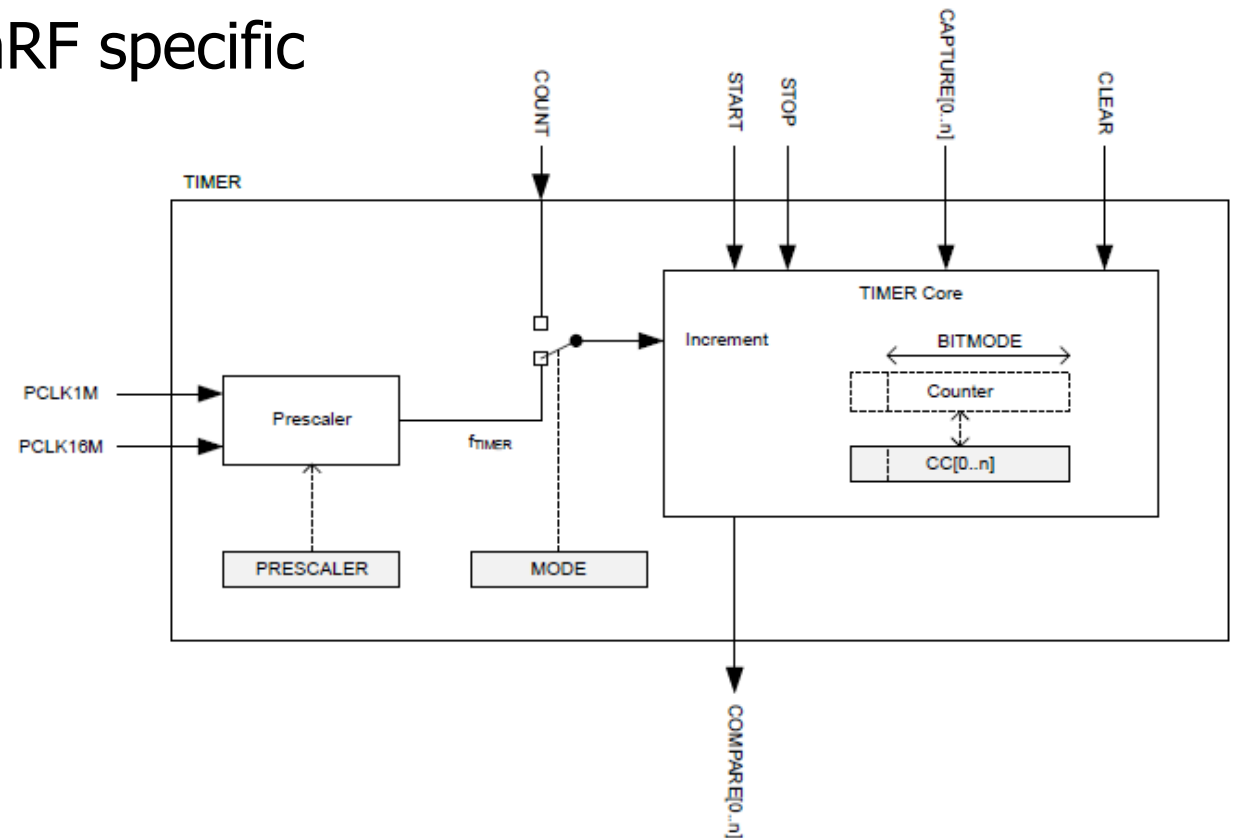

Usage: how do we set a one second timer?

- Assume timer is already running

1. Get current time from timer

2. Add 1 second worth of ticks to it

- $\frac{16000000}{2^{PRESCALER}}$ is the number of ticks per second

3. Set an unused Compare register to value

4. Enable interrupts for that Compare event

Warning: what if you're setting a 1 us timer instead? Or a 100 ns timer?

Timer could expire *before* software writes it to the peripheral.

Check your understanding

- Prescaler value is 4

$$f_{\text{TIMER}} = \frac{16 \text{ MHz}}{2^{\text{PRESCALER}}}$$

- Current internal Counter value is 0x1000
- Want a 0.5 second timer

- **What do you set the CC[0] register to? (32-bits)**

Check your understanding

- Prescaler value is 4

$$f_{\text{TIMER}} = \frac{16 \text{ MHz}}{2^{\text{PRESCALER}}}$$

- Current internal Counter value is 0x1000
- Want a 0.5 second timer

- **What do you set the CC[0] register to? (32-bits)**

- 1 MHz Timer frequency -> 500,000 ticks in 0.5 seconds
- 500000 -> 0x7A120
- Plus initial value of counter = **0x7B120**

Outline

- Clocks
- Timers
- **Virtualizing Resources**
- Real-Time Counter
- Watchdog

Choosing resource amounts is a problem

- Problem: applications may require any number of resources
 - Particularly in this case: peripherals
 - For example, how many timers should there be?
- But hardware has to pick some number to provide
 - More is wasted cost
 - Too few and applications cannot succeed
- Solution: virtualize the resource

Virtualization pattern

- Create a queue of requests and a pool of resources
 - N requests to M resources
- Application requests are queued when they come in
 - Rather than serviced immediately
- When a resource is available
 - Pop request from queue (by some priority)
 - Service with hardware
 - Then wait until another resource is available

Example: sending serial messages

- Serial messages (such as `printf()` strings) are sent via UART
 - UARTE peripheral (we'll talk about this later)
- nRF52 has two UARTE peripherals
 - Can be attached to any output pins
 - Changing pins is a quick operation
- What if we want to talk to three serial devices?
 - Console (`printf` output)
 - GPS (NMEA)
 - WiFi radio (AT commands)

Virtualized UART

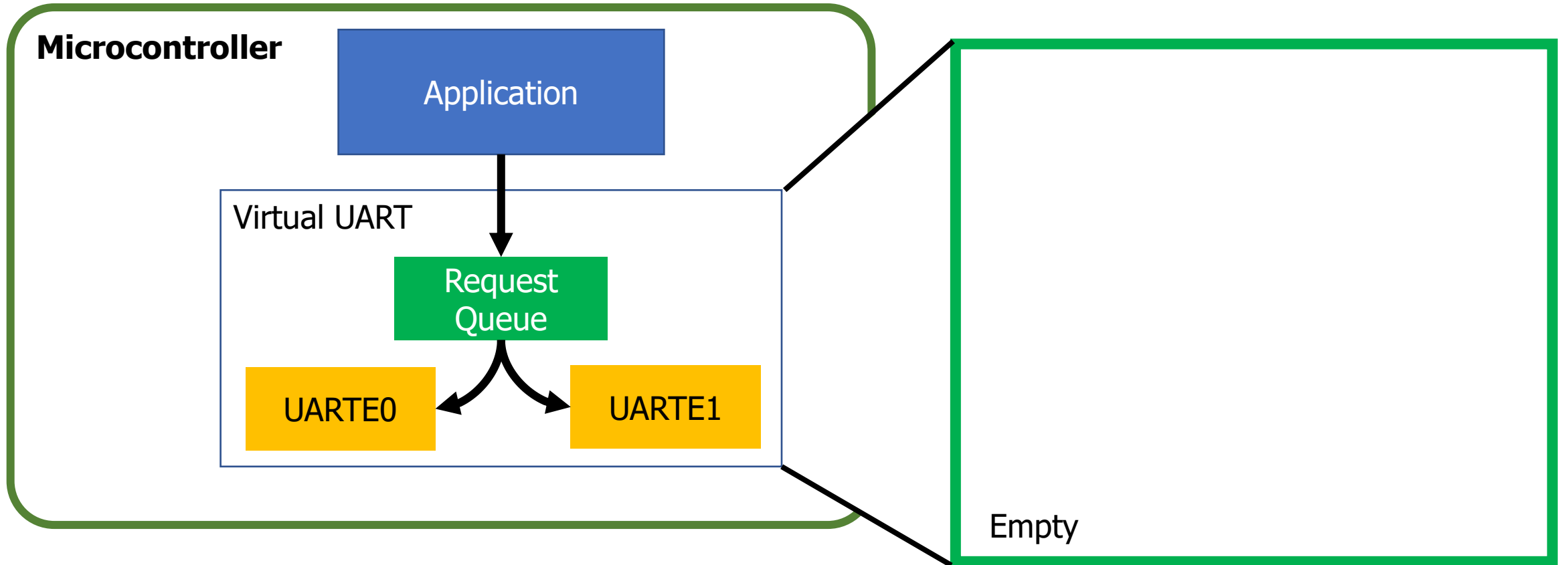

Serial Console

GPS

WiFi Radio

Virtualized UART: serves request with hardware

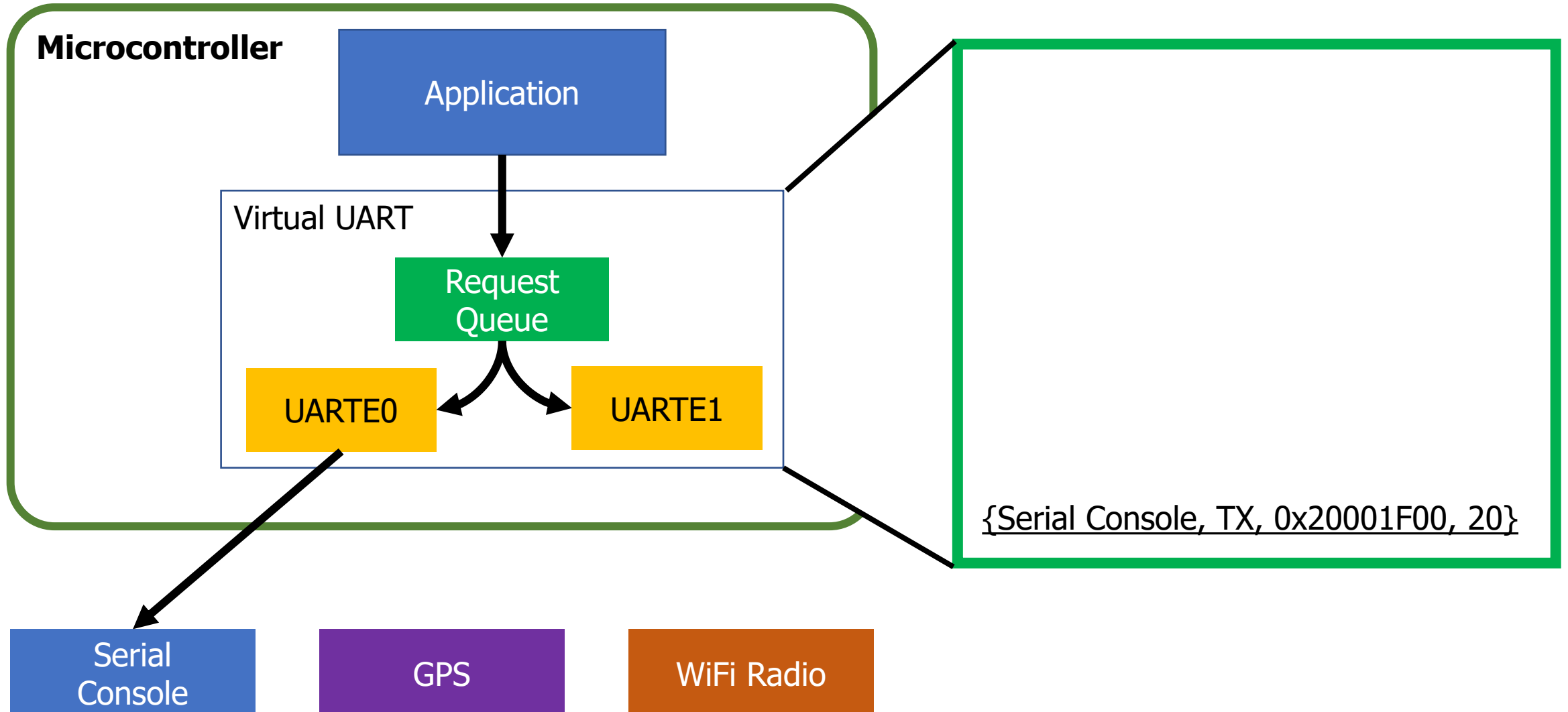

Virtualized UART: serves until resources are full

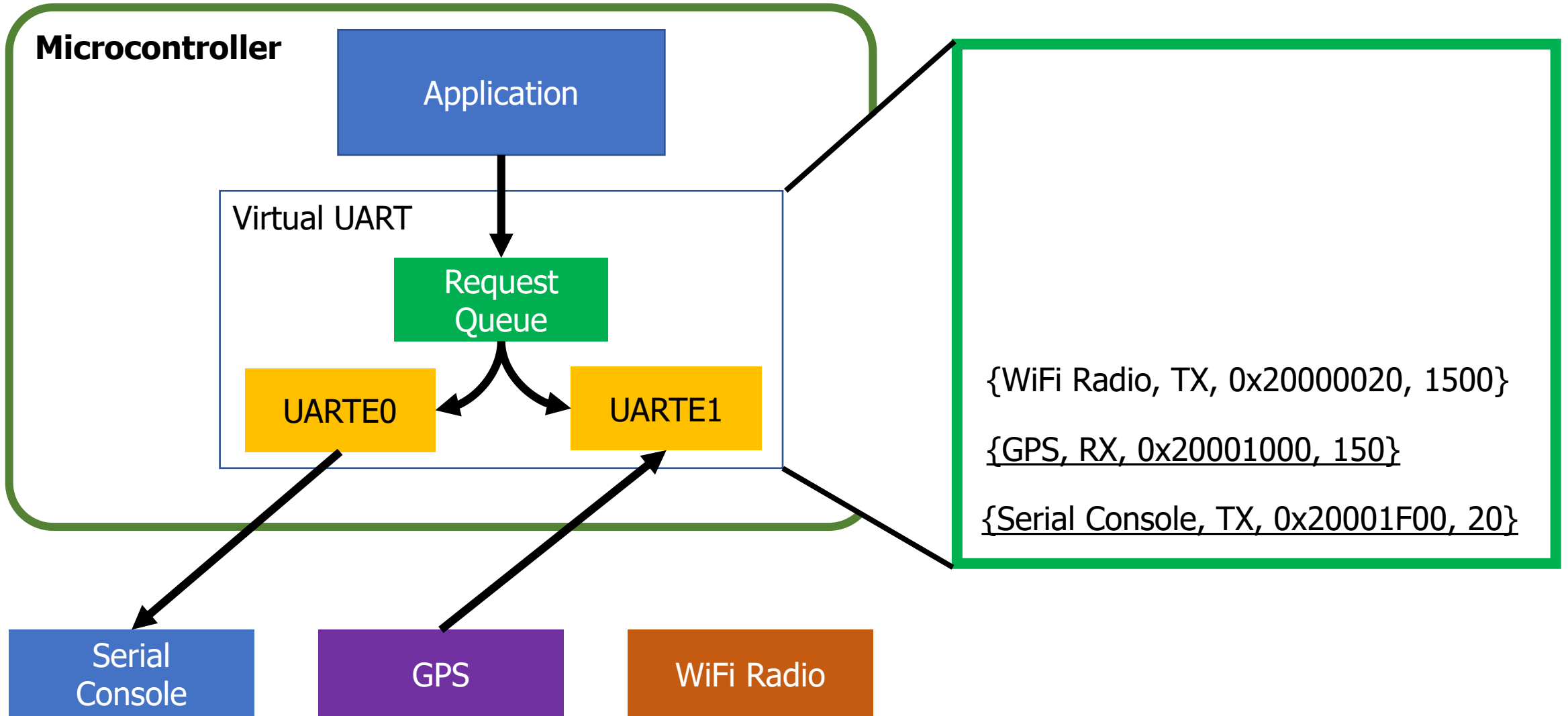

Virtualized UART: additional requests are queued

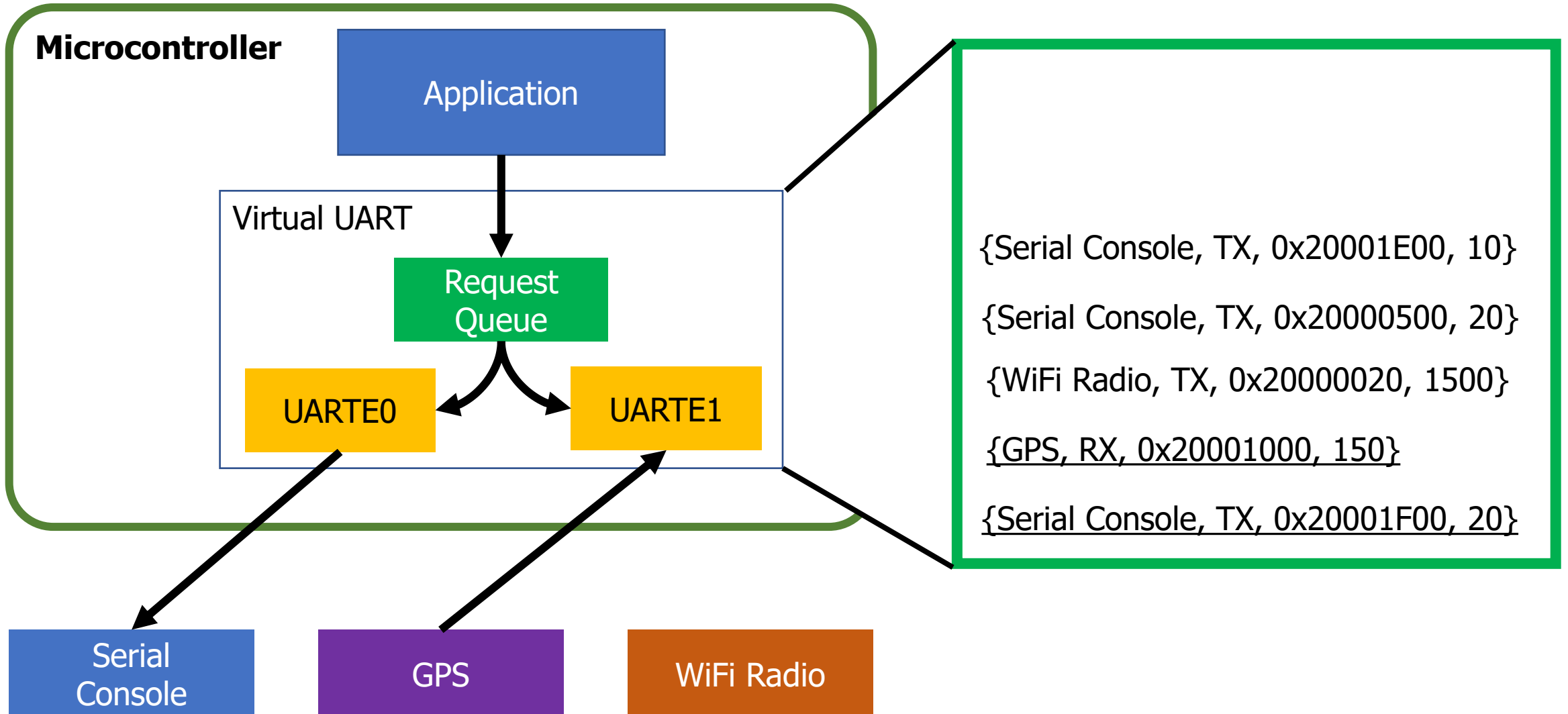

Virtualized UART: moves to next item when complete

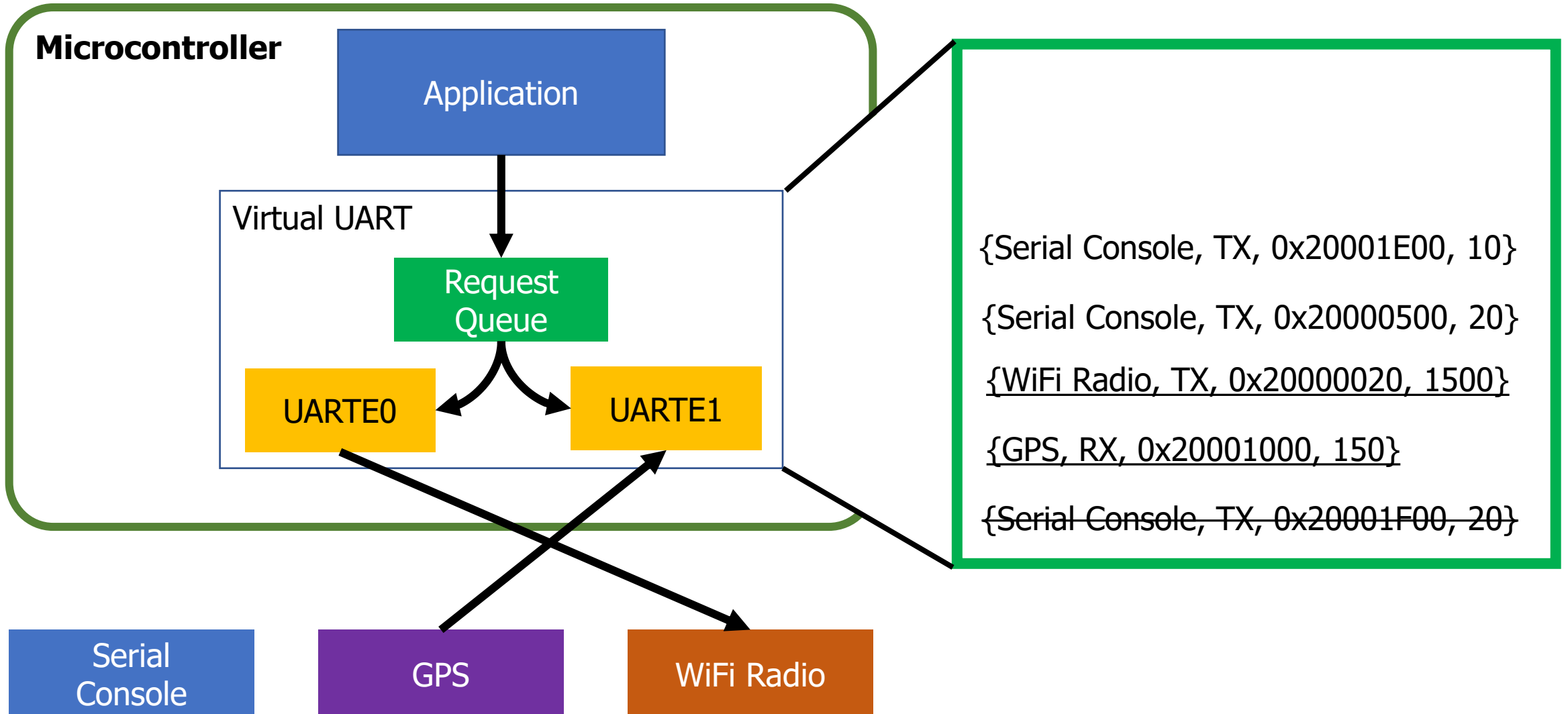

Virtualized UART: moves to next item when complete

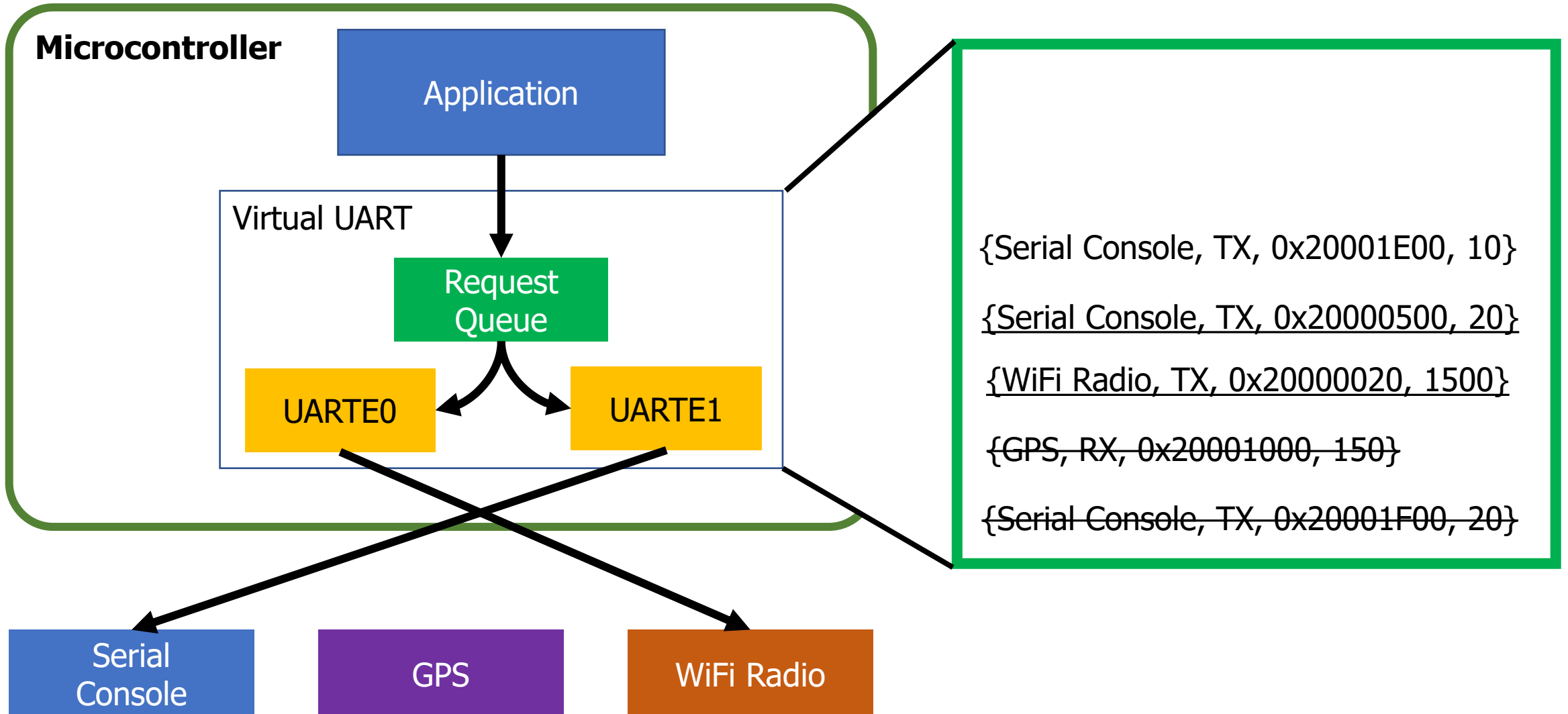

Challenges to making virtualization work

- How fast are requests coming in?
 - Requests more quickly than service are an unsatisfiable system
- How long does it take to reconfigure the resource?
 - Long delays could mean high latency
 - Might want to optimize for requests with same configuration first
- Need to ensure all of the configuration changes
 - Common bug: forget to modify part of one register and system works most of the time, but not in all cases
- Need ability to queue requests
 - Usually stored in a linked list structure
 - Dynamically... But we generally want to avoid dynamic memory

Dynamic resource allocation options

1. Create a queue with a maximum size in Virtual Driver
 - Some number larger than the hardware picked, based on app knowledge
 - Still either runs out or wastes memory
2. Just use malloc()
 - Is actually possible on the nRF52 with newlib (libc implementation)
 - Might run out, but then just wait for requests to complete
3. Create list nodes individually as global variables
 - Application decides how many it needs at compile time
 - Passes them into the Virtual Driver at first use
 - “Here’s my request and a linked list node to store it in”

Another example: managing multiple timers

- You often have tasks that look like this:

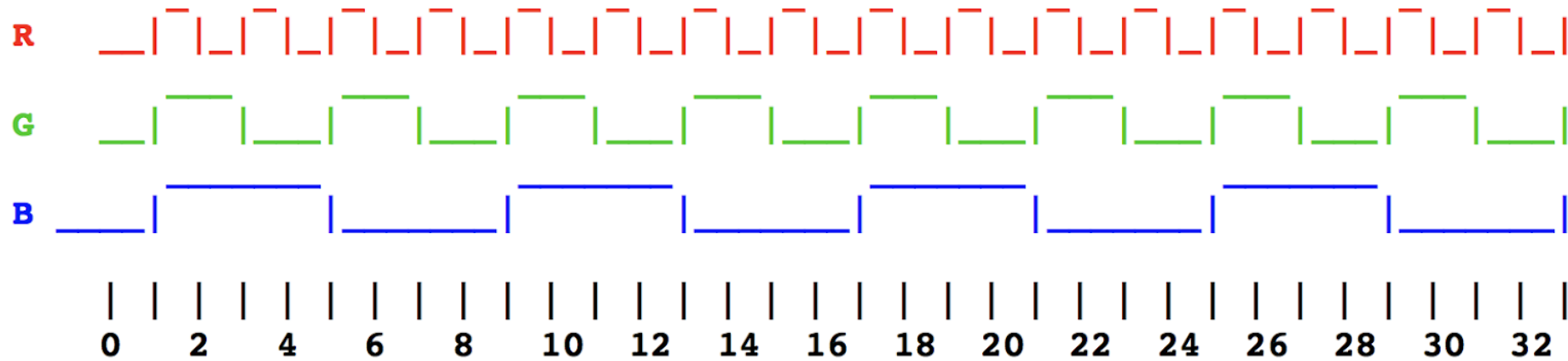

- Most easily thought about as three separate timers
 - But maybe the system doesn't have that many timers to spare!
 - Virtualization can help

Virtual timers

- Solution: keep a list of timer expiration times
 - Soonest expiration goes in the Capture/Compare register
 - Others stay in linked list, sorted by expiration

Timer Requests

1. 10010, A
2. 10050, B
3. 10110, C
4. 20000, D

CC Register: 10010



Virtual timers

- Solution: keep a list of timer expiration times
 - Soonest expiration goes in the Capture/Compare register
 - Others stay in linked list, sorted by expiration

Timer Requests

1. 10010, A
2. 10050, B
3. 10110, C
4. 20000, D

CC Register: 10010

Call timer handler A!
Update CC register and list



Virtual timers

- Solution: keep a list of timer expiration times
 - Soonest expiration goes in the Capture/Compare register
 - Others stay in linked list, sorted by expiration

Timer Requests

CC Register: 10050

1. 10050, B
2. 10110, C
3. 20000, D



Virtual timers

- Solution: keep a list of timer expiration times
 - Soonest expiration goes in the Capture/Compare register
 - Others stay in linked list, sorted by expiration

Timer Requests

1. 10050, B
2. 10110, C
3. 20000, D

CC Register: 10050

Call timer handler B!
Update CC register and list



Virtual timers

- Solution: keep a list of timer expiration times
 - Soonest expiration goes in the Capture/Compare register
 - Others stay in linked list, sorted by expiration

Timer Requests

CC Register: 10110

1. 10110, C
2. 20000, D



Virtual timers

- Solution: keep a list of timer expiration times
 - Soonest expiration goes in the Capture/Compare register
 - Others stay in linked list, sorted by expiration

Timer Requests

1. 10100, E
2. 10110, C
3. 20000, D

CC Register: 10100

New request arrives for 10100

Enqueue and sort queue

Update CC if first request has changed



Enqueueing timer requests

- Timer requests come in the form: {N seconds from now}
 - `timer_request(duration, handler);`
- Requests are always relative to the current time
- Need to enqueue by expiration time
 - Duration + Current Time
 - Allows for a globally sortable list
 - Need to decide how to handle overflow logic in real world

Make sure not to miss timers

- Sorting list and modifying the CC register takes time
 - Might have skipped right past the soonest event
 - Check for this, and call handler manually if necessary

Timer Requests

1. 10100, E
2. 10110, C
3. 20000, D

CC Register: 10100

Handle 10100 event, Call E



Make sure not to miss timers

- Sorting list and modifying the CC register takes time
 - Might have skipped right past the soonest event

Timer Requests

1. 10110, C
2. 20000, D

CC Register: 10110

Update list
Update CC register
Oh no! That's in the past!!



Break + Question

- Sorting list and modifying the CC register takes time
 - Might have skipped right past the soonest event
- What do we do about the missed timer?
 - There are multiple “correct” answers here

Break + Question

- Sorting list and modifying the CC register takes time
 - Might have skipped right past the soonest event
- What do we do about the missed timer?
 - There are multiple “correct” answers here
- **Some options:**
 - Just call handle that timer event as soon as possible
 - Possibly telling it about the delay
 - Crash the system! (Deadlines cannot be missed in some systems)
 - Or at least enter some fault recovery handler

Make sure not to miss timers

- Sorting list and modifying the CC register takes time
 - Might have skipped right past the soonest event
 - Check for this, and call handler manually if necessary

Timer Requests

1. 20000, D

CC Register: 20000

Call C manually
Update list and CC register again



Some timers are periodic

- Repeating timers are easy to add to this system
 - Include a Boolean for “repeating” and the duration in the request
- When timer expires
 - If not repeating, just call handler and then drop it
 - If repeating,
 - First reinsert based on duration and new current time
 - Then call the handler
 - Don’t want the latency of the handler to slow us down

Concurrency safety

- Modifying the request structure in an interrupt context is dangerous
 - New request might be in the middle of getting added
 - Interrupt would run right in the middle of that
 - Literally an OS data race example
- Solution: disable interrupts during critical section
 - Whenever editing request structure
 - Enable interrupts after, which may result in an event
 - Note: Interrupt handler might now fire but have no work to do. Should always check if something should actually be handled first

Outline

- Clocks
- Timers
- Virtualizing Resources
- **Real-Time Counter**
- Watchdog

Real-time Counter

- Low-power (32 kHz) version of Timer
 - Only a 24-bit internal Counter

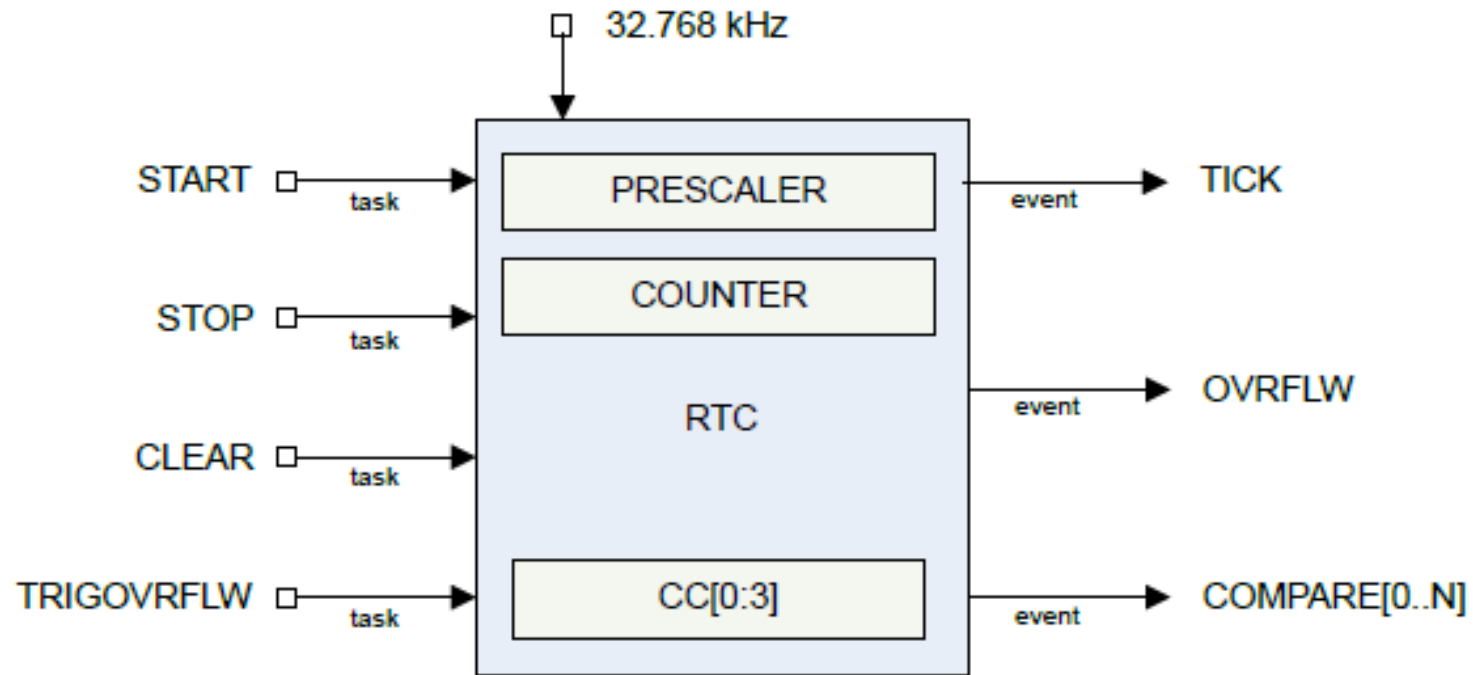

- Note: abbreviated RTC, but that already means something else (Real-Time Clock)

Differences between Real-Time Counter and Timer

- Runs off of LFCLK instead of HFCLK
 - With smaller prescaler value (4096 vs 32768)
- 24-bit counter vs 32-bit counter for Timer
- Can read the Counter value directly
 - No need for Capture task
- Otherwise extremely similar. Just a low-power version of Timer

Time resolution for Real-Time Counter

$$f_{\text{TIMER}} = \frac{32 \text{ KHz}}{\text{Prescaler}+1}$$

- Resolution
 - Minimum: 30.517 μs ticks, overflows in 512 seconds (24-bit Counter)
 - Maximum: 125 ms ticks, overflows in 582 hours
- Not as precise as the Timer (which has 62.5 ns best precision)
 - Possible design: use both
 - Real-Time Counter for most of the waiting
 - Chained into Timer for precise remaining amount of time

Comparing timer types

- Real-Time Counter
 - Low precision and duration
 - Low energy
- Timer
 - High precision or duration
 - High energy

Outline

- Clocks
- Timers
- Virtualizing Resources
- Real-Time Counter
- **Watchdog**

Reliable systems

- What's the most common way to solve computer problems?
 - Turn it off and turn it on again.

- **Why?**

Reliable systems

- What's the most common way to solve computer problems?
 - Turn it off and turn it on again.

- **Why?**

- Resets "state" to original values, which are likely good
 - Startup is often well-tested

 - It's long-running code interacting in unexpected ways that leaves systems in a broken state

Watchdog timer (WDT)

- Focused on failures where the system “hangs” forever
 - Maybe software, maybe hardware!
- Can't know for certain the system is hung, but can know practically
 - Select a timeout that is the maximum amount of time you expect the system to ever go without looping in main()
 - Multiply it by 2-10
 - Set a watchdog timer to that value
- If watchdog timer ever expires, it resets the system (in hardware)

Watchdog configuration

$$\text{timeout (seconds)} = \frac{\textit{Counter Reload Value} + 1}{32768}$$

- Configure watchdog
 - Can choose whether to count down during Sleep mode or Debug mode
- Set a Counter Reload Value (CRV, 32-bits)
- Start the watchdog timer
 - Loads internal Counter to CRV value
 - Starts counting down at 32 kHz

Running applications with a watchdog timer

- Need to periodically reset the watchdog to keep it from expiring
 - Known as “feeding” the watchdog or “kicking” the watchdog
- Reload Request register
 - Must write sequence 0x6E524635 to reload watchdog
 - Incredibly unlikely to happen by accident
- While running, watchdog is protected from modification
 - Configure once, run forever (at least until a reboot)
 - Only option is to make periodic Reload Requests
- Default off on the nRF52833 (default on for the MSP430!)

Outline

- Clocks
- Timers
- Virtualizing Resources
- Real-Time Counter
- Watchdog